

# Make:

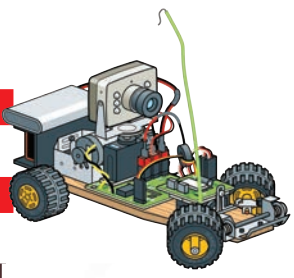

➤ Diagrams, step-by-steps, and resources for making your favorite projects!



# THE BEST OF

➤

# OF

## Volume 2

from the pages of Make:

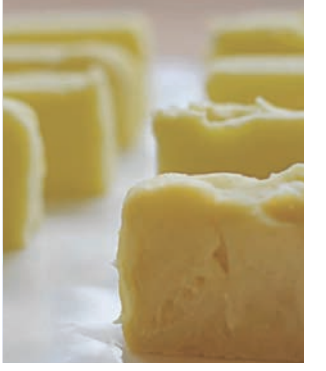

**THE  
BEST  
OF  
MAKE:**

Volume 2

# THE BEST OF MAKE:

## Volume 2

65 Projects and Skill Builders  
from the Pages of Make:

The Editors of Make:

## The Best of Make: Volume 2

### 65 Projects and Skill Builders from the Pages of Make:

By the Editors of Make:

Copyright © 2015 Maker Media, Inc. All rights reserved.

Printed in Canada.

Published by Maker Media, Inc.,  
1160 Battery Street East, Suite 125,  
San Francisco, California 94111

Maker Media books may be purchased for educational, business, or sales promotional use. Online editions are also available for most titles (<http://safaribooksonline.com>). For more information, contact our corporate/institutional sales department: 800-998-9938 or [corporate@oreilly.com](mailto:corporate@oreilly.com).

**Publisher:** Brian Jepson

**Editor:** Roger Stewart

**Production Editor:** Happenstance Type-O-Rama

**Proofreader:** Happenstance Type-O-Rama

**Interior Production:** Happenstance Type-O-Rama

**Cover Designer:** Brian Jepson

Special thanks to Craig Couden

See our webpage at [makezine.com/go/bom2](http://makezine.com/go/bom2)

September 2015: First Edition

#### Revision History for the First Edition

2015-09-15: First Release

See <http://oreilly.com/catalog/errata.csp?isbn=9781457186899> for release details.

Make:, Maker Shed, and Maker Faire are registered trademarks of Maker Media, Inc. The Maker Media logo is a trademark of Maker Media, Inc.

Many of the designations used by manufacturers and sellers to distinguish their products are claimed as trademarks. All trademarked and copyrighted products mentioned in the text are the property of their respective owners, and Maker Media, Inc., makes no claims of ownership by mentioning the products that hold these marks.

While the publisher and the author have used good faith efforts to ensure that the information and instructions contained in this work are accurate, the publisher and the author disclaim all responsibility for errors or omissions, including without limitation responsibility for damages resulting from the use of or reliance on this work. Use of the information and instructions contained in this work is at your own risk. If any code samples or other technology this work contains or describes is subject to open source licenses or the intellectual property rights of others, it is your responsibility to ensure that your use thereof complies with such licenses and/or rights.

978-1-680-45032-3

[TCP]

# CONTENTS

We're All Makers <i>by Keith Hammond</i> . . . . .	vii
The Maker's Bill of Rights <i>by Mister Jalopy</i> . . . . .	ix
Right to Repair <i>by Kyle Wiens</i> . . . . .	x
<b>Part 1: Workshops and Tools</b> . . . . .	<b>1</b>
The Ultimate Tool Buying Guide <i>by the Editors of Make:</i> . . . . .	2
Building the Barrage Garage <i>by William Gurstelle</i> . . . . .	4
Choose Your Tools <i>by William Gurstelle</i> . . . . .	8
Stock Your Shop <i>by William Gurstelle</i> . . . . .	14
The Safe Workshop <i>by William Gurstelle</i> . . . . .	16
Lost Screw Finder <i>by Frank Ford</i> . . . . .	17
Mini Fume Extractor <i>by Marc de Vinck</i> . . . . .	19
Understanding Basic Woodworking Tools <i>by Len Cullum</i> . . . . .	22
Japanese Toolbox <i>by Len Cullum</i> . . . . .	27
Wilderness Workshop <i>by Charles Platt</i> . . . . .	34
<b>Part 2: Electronics</b> . . . . .	<b>39</b>
Your Electronics Workbench <i>by Charles Platt</i> . . . . .	40
Servomotors <i>by Tod E. Kurt</i> . . . . .	45
Listening to Satellites <i>by Diana Eng</i> . . . . .	52
The Eclectic Electret Microphone <i>by Charles Platt</i> . . . . .	58
The Bobbinator <i>by Andrew Lewis</i> . . . . .	60
Keybanging <i>by William Gurstelle</i> . . . . .	62
Surface Mount Soldering <i>by Scott Driscoll</i> . . . . .	67
Desktop Digital Geiger Counter <i>by John Iovine</i> . . . . .	74
<b>Part 3: Microcontrollers and Microcomputers</b> . . . . .	<b>85</b>
Million Color HSL Flashlight <i>by Dan Rasmussen</i> . . . . .	86
Hack Electronic Pushbuttons <i>by Peter Edwards</i> . . . . .	92
X10 Arduino Macro Module <i>by Jim Newell</i> . . . . .	96
Advanced Arduino Sound Synthesis <i>by Jon Thompson</i> . . . . .	102
Raspberry Pirate Radio <i>by Sam Freeman and Wynter Woods</i> . . . . .	110
How to Bake an Onion Pi <i>by Limor Fried and Phil Torrone</i> . . . . .	112
<b>Part 4: 3D Printing and CNC Fabrication</b> . . . . .	<b>119</b>
CNC Maker Bench <i>by Anna Kaziunas France</i> . . . . .	120
The Skinny on End Mills <i>by Tyler Worman</i> . . . . .	124
Cyberpunk Spikes <i>by Becky Stern and Phillip Burgess</i> . . . . .	126
3D-Printed Pinhole Camera <i>by Todd Schlemmer</i> . . . . .	130
CNC Air Raid Siren <i>by Dan Spangler</i> . . . . .	134
<b>Part 5: Robots and Drones</b> . . . . .	<b>135</b>
Beetlebot <i>by Jérôme Demers</i> . . . . .	136
My Robot, Makey <i>by Kris Magri</i> . . . . .	140
How to Build CoffeeBots <i>by Judy Aime' Castro</i> . . . . .	152
Anatomy of a Drone <i>by the Editors of Make:</i> . . . . .	160
Finding Your Way with GPS <i>by Mikal Hart</i> . . . . .	162
Build Your First Tricopter <i>by Lucas Weakley</i> . . . . .	166
The Handycopter UAV <i>by Chad Kapper</i> . . . . .	172

<b>Part 6: Music and Audio.</b>	<b>179</b>
Traditional Cigar Box Guitar by <i>Mark Frauenfelder</i>	180
Squelette, the Bare-Bones Amplifier by <i>Ross Hershberger</i>	190
Laser Harp by <i>Stephen Hobley</i>	206
Solar Xylophone by <i>Rory Nugent</i>	212
MonoBox Powered Speaker by <i>Ross Hershberger</i>	222
Electronic Drum Kit by <i>Tom Zimmerman</i>	232
<b>Part 7: Photography and Video.</b>	<b>239</b>
Spin the Birdie by <i>Larry Cotton</i>	240
Helium Balloon Imaging “Satellite” by <i>Jim Newell</i>	250
Looking at the Low End by <i>Richard Kadrey</i>	260
Go Green! by <i>Bill Barminski</i>	263
Brownie Pan LED Light Panel by <i>Tyler Winegarner</i>	266
Glass Bead Projection Screen by <i>Sean Michael Ragan</i>	268
Homebrew Digital 3D Movies by <i>Eric Kurland</i>	272
<b>Part 8: Fun and Games</b>	<b>279</b>
Retro R/C Racer by <i>Frank E. Yost</i>	280
The Most Useless Machine by <i>Brett Coulthard</i>	292
The Atlatl by <i>Daryl Hrdlicka</i>	301
G-meter and Altimeter by <i>David Simpson</i>	305
Living Room Baja Buggies by <i>John Mouton</i>	309
Boom Stick by <i>Edwin Wise</i>	319
Wooden Mini Yacht by <i>Thomas Martin</i>	329
<b>Part 9: Crafts and Wearables.</b>	<b>333</b>
Sous Vide Immersion Cooker by <i>Scott Heimendinger</i>	334
Making Bar Soap by <i>Alastair Bland</i>	346
Three-Day Kimchi by <i>Wendy Jehanara Tremayne</i>	349
Luminous Lowtops by <i>Clayton Ritcher</i>	350
Flora NeoGeo Watch by <i>Becky Stern and Tyler Cooper</i>	354
The Chameleon Bag by <i>Kathryn McElroy</i>	360
Pipe Dreams by <i>Larry Cotton and Phil Bowie</i>	363
Stain PVC Any Color by <i>Sean Michael Ragan</i>	375
DIY Conductive Ink by <i>Jordan Bunker</i>	376

# We're ALL Makers >>>>>>

A quizzical little magazine called *Make:* appeared in bookstores and on newsstands in 2005, stuffed with geeky DIY projects like “Kite Aerial Photography” and a hacked VCR Cat Feeder. And I do mean “little”—its small format was eye-catching, more like a paperback book than a traditional magazine. Suffice it to say, *Make:* got noticed by a new generation of readers itching to take technology into their own hands and get building things. I hopped aboard as a humble copyeditor, and it's been my great privilege to ride the wave ever since—surfing along at the forefront of a burgeoning Maker Movement. We published *The Best of Make:* in November 2007, collecting 75 beloved projects from our first 10 issues.

Then things got really busy. The *Make:* website took off like a rocket, posting maker news and projects every day. Our “Weekend Projects” video series broke out on YouTube. *Craft:* magazine inspired a new audience to transform traditional crafts. Maker Faire began in 2006 as a Bay Area DIY festival and erupted into a global phenomenon, with Faires in New York, London, Shenzhen—more than 100 cities in 2015. We launched our *Make:* books imprint, as well as the Maker Shed store to purvey the finest in DIY books, kits, and tools. Two years ago, Maker Media, Inc., spun off from O'Reilly Media. We moved our digs to San Francisco and relaunched the magazine in a full-size format aimed at a wider audience, kicking off our most exciting chapter yet.

Next thing we know, *Make:* is 10 years old, with editions published in China, Japan, and Germany, and as of this writing we're coming up on our 50th issue. It's time we served up another slice: *The Best of Make: Volume 2*—65 great projects and skill builders for all levels.

Change accelerates, but the essence of *Make:* is eternal—people just love making things and learning new skills.

While we delight in chronicling the brilliant makers and powerful new tools that are driving the Maker Movement, to my mind it's the DIY projects and tutorials that remain at the heart of *Make:* magazine. We'll always teach you to solder new circuits and MacGyver new gadgets from old—it's what we do.

Have the projects changed over the years? Absolutely. Technology waits for no one. Laser cutters are everywhere now. CNC routers and personal 3D printers have evolved from quirky prototypes—remember the plywood MakerBot on the cover of *Make: Volume 21*?—into smart, reliable tools for new kinds of making, like fashionable, flexible 3D printed “Cyberpunk Spikes” or an ear-splitting “CNC Air Raid Siren.”

And drones—radio-controlled aircraft with the robotic brains to level themselves, fly acrobatically, and even navigate autonomously—went from faraway headlines to the familiar multirotor copters (like you'll find in “The HandyCopter UAV” and “Build Your First Tricopter”) that everyone's nephew is building and flying today.

Maybe most significant, the rise of inexpensive microcomputers you can

embed in almost any project—from Arduino microcontrollers to credit-card-sized Linux computers like the Raspberry Pi—has made possible new kinds of inventions, like a “Million Color HSL Flashlight” or a “Raspberry Pirate Radio.”

And if Maker Faire has taught us anything, it’s the enormous variety of people who identify themselves as makers. We’ve discovered new communities of DIY innovators, in traditional arts and crafts reshaped by digital design, in wearable electronics (“Luminous Lowtops”), and in modernist cuisine, ranging from new cooking technology (“Sous Vide Immersion Cooker”) to the art and science of fermented foods (“Three-Day Kimchi”).

The projects in this book cover a very wide range of topics, for every skill level—from robots and rockets to making soap—because we see all makers as part of the Maker Movement. I’m most satisfied with *Make*: when it’s a variety show like Maker Faire: high tech meets arts and crafts, garage engineering, backyard science, a big portion of family fun, peppered with delightfully unclassifiable projects.

Why would you build “The Most Useless Machine”? How could you not?

As I scan the projects in this book, I’m overwhelmed by happy memories of the entire *Make*: editorial and creative teams, anchored over the years by Dale Dougherty, Mark Frauenfelder, Paul Spinrad, Shawn Connally, Goli Mohammadi, Gareth Branwyn, Mike Senese, Jason Babler, and our new chief, Rafe Needleman. I have them to thank for my sense of what *Make*: is and what it can become.

But really I’d like to thank the makers whose words you’ll read in this book. For sharing their projects and workshops, their tips and tricks, and their genuine joy in making things and showing you how to make them too. It’s that spirit of glee and generosity that moves the Maker Movement. You’ll find it in abundance in these pages. It’s a wellspring you can drink from again and again.

—KEITH HAMMOND, Projects Editor, *Make*:

P.S. What will *Make*: be ten years from now? You tell me! E-mail me your delightful projects at [khammond@makermedia.com](mailto:khammond@makermedia.com).



# THE MAKER'S BILL OF RIGHTS

If you can't open it, you don't own it.

Ease of repair shall be a design ideal, not an afterthought. <sup>1</sup>

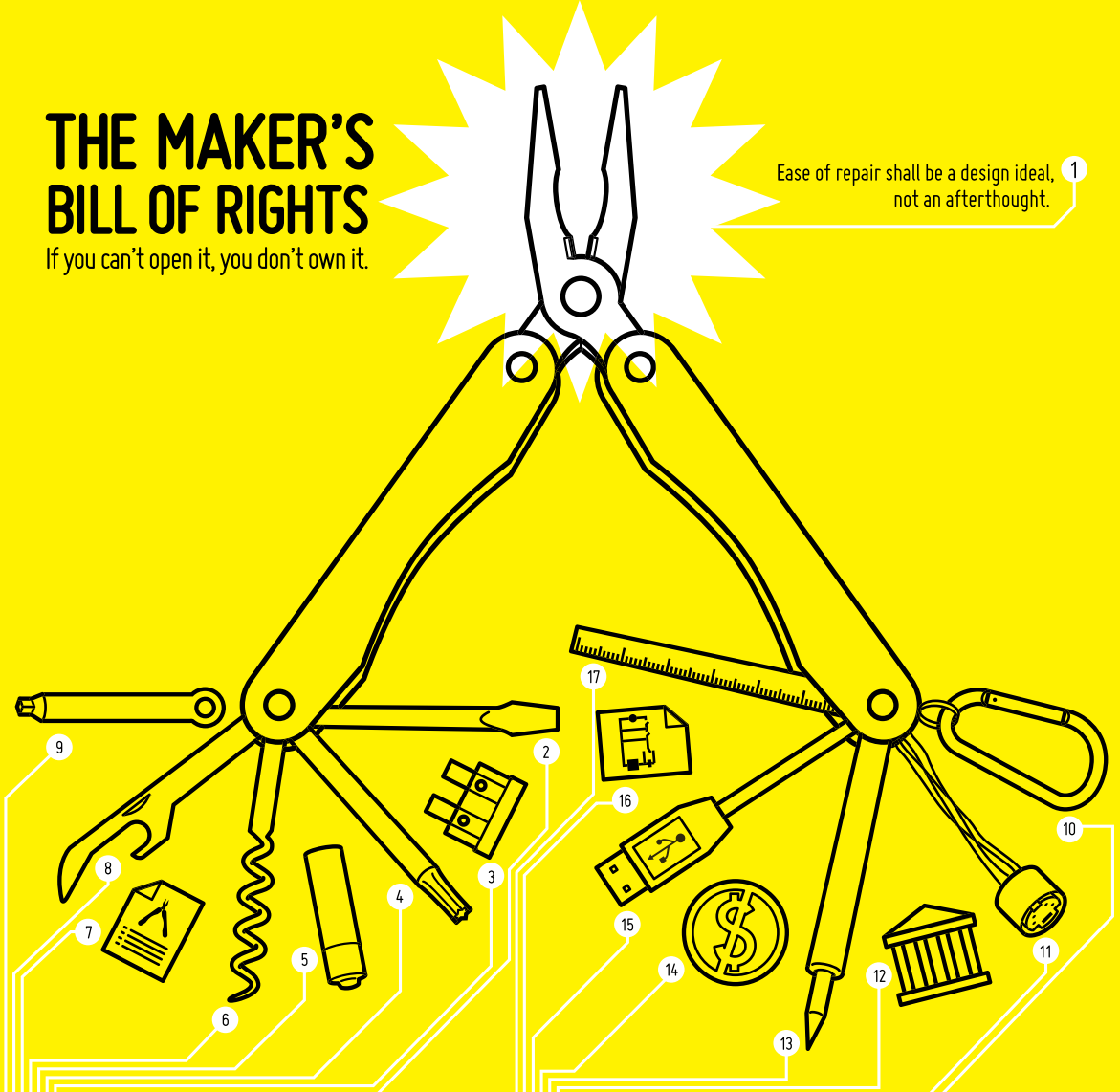

- 2 Screws better than glues.
- 3 Consumables, like fuses and filters, shall be easy to access.
- 4 Torx is OK; tamperproof is rarely OK.
- 5 Batteries shall be replaceable.
- 6 Special tools are allowed only for darn good reasons.
- 7 Meaningful and specific parts lists shall be included.
- 8 Cases shall be easy to open.
- 9 Components, not entire subassemblies, shall be replaceable.

- 10 If it snaps shut, it shall snap open.
- 11 Standard connectors shall have pinouts defined.
- 12 Docs and drivers shall have permalinks and shall reside for all perpetuity at [archive.org](http://archive.org).
- 13 Circuit boards shall be commented.
- 14 Profiting by selling expensive special tools is wrong, and not making special tools available is even worse.
- 15 Power from USB is good; power from proprietary power adapters is bad.
- 16 Schematics shall be included.
- 17 Metric or standard, not both.

Illustration by James Provost

# Right to Repair

Fight for your right to truly own your things.

Written by Kyle Wiens ■ Illustration by Jim Burke

## IF MY PHONE WERE A PERSON, IT WOULD BE THE BIONIC WOMAN.

Its body has been broken and rebuilt more times than I can count. Its brain has been modified, tinkered with, and improved.

In the past three years, my iPhone 4S has been jailbroken and wired into a home automation system. Its Apple-approved glass back panel has been replaced with a transparent one. It's been water-drenched, dismantled, and completely cleaned. Twice. Thanks to an app from the free-as-in-speech Cydia store, I'm tracking my battery's performance in ways Apple won't allow. And I've pried up and replaced that battery over and over again.

It's the phone that will not die — at least not if I have anything to say about it.

Ten years ago, I started iFixit, the world's free online repair manual. Our goal is to teach everyone how to fix the stuff they own — whether it's laptops, snowboards, toys, or clothes. And we're not alone. iFixit is part of a global network of fixers trying to make the stuff we own last forever.

On the surface, fixers and makers are cut from different cloth. Makers put things together; fixers take them apart. One creates new gizmos; the other rebuilds existing ones. But I've always thought that, under the skin, they're incredibly similar — two different sides of the same coin.

We are, all of us, tinkerers. We're motivated by the same ideals: an inexhaustible curiosity, an appreciation for things done by hand, a sentimental attachment to the smell of wood shavings, and a never-ending pursuit of understanding the things around us.

As tinkerers, we become more than just consumers. We are participants in the things we make, own, and fix. But over the years, I have found that this participation — tinkering with products made by others — puts both makers and fixers at odds with manufacturers. (Apple certainly wouldn't endorse

my bionic iPhone.) For the most part, manufacturers would prefer if we all just put down our screwdrivers and got back in line at the store.

By revealing (and reveling in) the secret insides of machines, tinkerers transgress the boundaries of what manufacturers think we should be able to do with our stuff. We alter the code they wrote, we rebuild the hardware they designed, and we find ways of fixing our old stuff instead of buying their new stuff.



For the past 20 years, manufacturers have been waging a quiet war against tinkerers like us. They're using encryption-powered DRM, vague hand-waving claims of proprietary knowledge, DMCA takedown notices, and legal threats to keep people from fixing their tractors, from repairing their Apple products, and even from modifying the software on their calculators. Keurig is even adding a chip to their coffee pods to prevent

homebrewers from "reloading" their capsules.

It took two years after 114,000 people signed a We-the-People petition to finally relegalize cell phone unlocking, but we did it! Unfortunately, despite intensive right-to-repair lobbying from the Electronic Frontier Foundation and others, jailbreaking game consoles and bypassing digital locks on tractors is still a crime.

Even the car industry — sacred ground for tinkerers since the rise of the hot rod — has succumbed to the same locked-door policies. These days, cars are made up of as much code as they are nuts and bolts. Tinkering under the hood requires access to service information and schematic systems — information that carmakers don't like to share.

In Massachusetts, voters had to pass a law to force automakers to share internal service manuals, circuit diagrams, and computer codes with independent repair shops and owners.

I think that if you bought it, you own it. I mean *really* own it. You have the right to take it apart, mod it, repair it, tap dance in the code, or hook it up to your personal brand of Arduino kung-fu.

But if you want the right to tinker, you'll have to start fighting for it. Fight for your right to mod and make. Fight for your right to repair. Fight for your right to own your own things.

We live in a brave new digital world, and it's time that we join forces with Cory Doctorow — and other makers leading the movement to free our hardware — when he says, "This has nothing to do with whether information is free or not — it's all about whether people are free." 🚫

---

**KYLE WIENS** is the cofounder of iFixit ([ifixit.org](http://ifixit.org)), the free repair manual. iFixit's open-source community has taught millions of people how to fix everything from iPhones to Volvos

**Y**ou may have first encountered William Gurstelle in the pages of one of his many best-selling books, such as *Backyard Ballistics* or *The Practical Pyromaniac*. If so, you will understand why he calls his workshop “The Barrage Garage.”

Bill is a regular contributor to *Make:* magazine, and his workshop articles form the centerpiece of this opening section of *The Best of Make: Volume 2*. Every maker needs a workspace and tools. Whether you decide to convert an existing space or build from scratch like Bill did, you’ll find lots of tips for designing, stocking, and organizing your own workshop in his contributions to this collection.



Another long-time contributor to *Make:* magazine, Charles Platt, is the author of the leading book for electronics enthusiasts, *Make: Electronics*. In addition to his well-known passion for electronics, Charles is also accomplished with a wide range of workshop tools. In “Wilderness Workshop,” he shares the economical ways he found to furnish his workspace that overlooks the wilds of Northern Arizona.

Master craftsman Len Cullum provides an introduction to basic woodworking tools, as well as the tools he finds most useful for making accurate measurements. In his article, “Japanese Toolbox,” he shows you how to build a versatile storage box for your workshop tools. Simplicity and elegance are the hallmarks of Len’s work.

Frank Ford also knows something about simplicity and elegance. He is an

accomplished maker of stringed musical instruments, and you will find a treasure trove of information about fretted instrument repair, maintenance, and restoration on his website [frets.com](http://frets.com). Frank turns his ingenuity to a completely different task in his contribution to this volume, as he demonstrates a neat trick for recovering the tiny, hard-to-find things that often get dropped when you’re working on a project.

Marc De Vinck, a former director of product development at Maker Media, is now a professor in the technical entrepreneurship program at Lehigh University. While at Maker Media, Marc implemented the popular “Learn to Solder” program that is now a staple at Maker Faire and has taught thousands of people this valuable skill. His “Mini Fume Extractor” project is especially clever because he uses his soldering iron to create a handy little tool to pull fumes away from his soldering projects. Now, that’s meta!

Enjoy discovering the tips and tricks of these workshop masters, and get ready to start making your own ideas into reality.



# THE ULTIMATE TOOL BUYING GUIDE

A complete list of tools you need to make almost anything.

If a genie were to grant me my wish for a shed full of tools, this is what I'd ask for. Think of it as an extremely biased guide to outfitting yourself with the ultimate shop for launching your own space program.

<span style="background-color: black; color: white;">■</span>	Necessity
<span style="background-color: darkred; color: white;">■</span>	Priority
<span style="background-color: red; color: white;">■</span>	Extremely useful
<span style="background-color: orange; color: white;">■</span>	Surprisingly useful
<span style="background-color: yellow; color: black;">■</span>	Infrequent but handy
<span style="background-color: lightyellow; color: black;">■</span>	Can do without, better with
<span style="background-color: lightblue; color: black;">■</span>	You didn't know it was so lovely
<span style="background-color: blue; color: white;">■</span>	Bonus

Tool Name	McMaster #	\$ Budget	\$ Deluxe
<b>Hand Tools</b>			
<b>Box Knife</b>	3814a11	1	10
<b>Precision Blade</b>	35435a11 38995a71 35515a12	1	10
<b>Claw Hammer</b>	6484a21	10	50
<b>Ball Peen Hammer</b>	6481a31	10	50
<b>Blacksmith's Hammer (Heavy Weight)</b>	6462a24	10	80
<b>Rubber Mallet</b>	5917a8	10	40
<b>Miter Box</b>	4201a11	15	45
<b>Hacksaw</b>	4086a34	5	25
<b>Tight Spot Hacksaw</b>	4060a16	2	5
<b>Hole Punch Tool</b>	3461a22	40	150
<b>Center Punches and Chisel Set</b>	3506a76	25	120
<b>Metric and Imperial Socket Sets</b>	7290a24 5757a35 5582a11	30	1200
<b>Torque Wrench</b>	85555a221	50	300
<b>Hex Key Sets, Imperial and Metric</b>	5541a31 5215a24 7162a13 5215a12	2	80
<b>Torx Key Set</b>	6959a85	2	40
<b>Mini-Hex Drivers</b>	52975a21 7270a59	2	40
<b>Combination Wrenches, Metric and Inch</b>	5314a62 5304a73 5314a25 5772a53	25	800
<b>Vise Grip Long Nose Locking Pliers</b>	7136a19	2	50
<b>Needlenose Pliers, Small and Large</b>	5451a12	2	35
<b>Bull Nose Pliers, Small and Large</b>		2	35
<b>Vise Grip, Large</b>	7136a15	5	60
<b>Vise Grip, Med Curved</b>	5172a17	5	45

Tool Name	McMaster #	\$ Budget	\$ Deluxe
<b>Adjustable Wrenches</b>	5385a12 5385a15	3	40
<b>Crow Bar / Ripping Bar</b>	5990a2	2	30
<b>Tube Cutter</b>	2706a1	15	80
<b>Glass Cutter</b>	3867a16	2	25
<b>Bolt / Chain Cutter</b>	3771a15	50	150
<b>Sheet Metal Snips</b>	3585a13 3908a11 3902a9	10	40
<b>Finishing Saw</b>	4012a1	10	30
<b>Coping Saw</b>	4099a1 6917a11	4	10
<b>Hole Saw Kit</b>	4008a71	25	120
<b>Pull Saw</b>	4058a52	10	20
<b>Metric / Inch Tap and Die</b>	2726a66	40	1200
<b>Drill Sets</b>	28115a77 31555a55 31555a56 31555a57 8802a11 8802a12 8802a13	5	1200
<b>Deburring Taper</b>	3018a4	5	80
<b>Deburring Tools</b>	4253a16 4289a36	2	25
<b>Drill Stops</b>	8959a16	2	10
<b>Vise</b>	5344a31	10	1500
<b>Clamps</b>	5165a25	2	45
<b>Quick-Grips</b>	51755a7	15	50
<b>Jaw Puller</b>	6293k12	50	180
<b>Files</b>	8176a12 8194a12	2	100
<b>Hydraulic Floor Jack</b>		25	200
<b>Block And Tackle / Lifting Winch</b>		50	500
<b>Screwdrivers, Flat and Phillips</b>	8551a31	1	90
<b>Jeweller's Screwdrivers</b>	52985a21 52985a23	10	40

Tool Name	McMaster #	\$ Budget	\$ Deluxe
Propane Burner		10	50
Heat Gun		50	250

## Power Tools

18V Electric Drill	29835a16	25	300
Band Saw	4164a12	250	5000
Reciprocating Saw (Sawzall)	4011a25	120	250
Sliding Compound Miter Saw	3001a21	200	600
Tilting Table Saw	27925a12	300	2000
Drill Press	28865a31	100	2500
Plunge Router	36485a11	100	300
Manual Lathe	8941a12	500	5000
Mig Welder	7899a28	200	1500
Stroboscope	1177t92	25	250
Adjustable Hot Plate	33255k61	50	800
Dremel	4344a42 4370a5	50	150
Angle Grinder	4395a16	50	250
Bench Grinder	20535A654	75	300
Belt Sander	4892a21	100	200
Disc / Belt Sander	46245a49	250	1500
Bridgeport Mill		500	15000
Heisseschneider Hot Knife		50	200
Sewing Machine		25	2500
Air Compressor	4364k3	200	2500
Spot Blaster	31195k11 3210k11	50	500
Vacuum Pump		100	1000+
Oxy / Acetylene Torch	7754a12	250	1500
Plasma Torch		600	3000

## Computer Controlled Tools

Inkjet Printer		25	250
Large-Format Printer		900	25000
Nc Mill		2500	120000
Nc Lathe		5000	150000
Laser Cutter (Co2)		12000	50000
Plasma Cutter		3000	20000
Wire / Sink EDM		100000	250000
Water Jet		80000	150000
3D Printer (Z Corp, FDM, STL)		25000	250000
Plotter / Cutter (Roland)		1000	25000

## Electronics Tools

Wire Stripper		2	80
Pliers Set	5323a49	10	120
Work Holder And Magnifier	5007a14	5	100
Multimeter		75	250
Temp-Control Solder Station		150	1000
Hot Air Tool for Point Reflow / Desoldering		30	500

Tool Name	McMaster #	\$ Budget	\$ Deluxe
Bench Power Supply, Multi-Output		150	500
Toaster Oven, Adjustable Time / Temp		40	60

Microscope (See Safety / Measurement / Visualization)			
Oscilloscope		500	5000
Micro-tweezer Sets		2	100
Pick-n-Place		3000	25000

## Fetish Tools

Optics Bench		1000	400000
Mask Writer		50000	1000000
Mini-jector		4000	50000
Thermoformer		1000	20000
ESEM		25000	500000
3D Scanner		5000	100000
Excimer Laser Cutter		100000	1000000
PCR			100000
Micropipettes		20	2000
Spin Coater		500	25000
High Temp / Vacuum Oven		2000	30000
Chemistry Hoods and Glass Equipment		2000	1000000
Ultrasonic Welder		5000	25000
Tube Bender		1000	40000
Tanks for Anodizing, Etching		25	2500
Kiln		500	5000
Anvil		250	1000
Crucible		20	2500
Thin Film Evaporator / Sputterer		5000	100000

## Safety, Measurement, and Visualization

Safety Goggles	2404t21	1	10
Ear Muffs	9205T6	2	30
Micrometer	2054a75	5	300
Caliper	8647a44	5	500
Head-Mounted Magnifier	1490t3 1509t14	5	120
Feeler Gauges	2070a7	1	25
Spirit Level	2169a4 2169a1	5	50
Tape Measure	19805a74	1	25
Adjustable Stereomicroscope	10705t64	500	25000
Hot Gloves		5	100
Work Gloves		1	40
Welding Mask		15	100
Rules	2042a77 6823a61 20265a36	5	100
Shop Vac	70215t26	60	200

# Building the Barrage Garage

The ultimate, multipurpose maker's workshop, built from the ground up.

By William Gurstelle



As a city dweller, I've often looked with envy at the spacious outbuildings of my rural friends and relatives. Horse barns, potting sheds, root cellars, equipment garages—plentiful, enclosed, and private space is the one thing that makes me envy those who live beyond the end of the bus line. I think often about what I could make if I had a room of my own: a purpose-built, well-equipped space in which to create.

Apparently I'm not alone in these thoughts. Homebuilders commonly offer two-, three-, and even four-car garages for new homes. But all that space isn't needed simply to shelter the family Chevy. It's needed to keep pace with the explosion in DIY projects and their concomitant material and tool requirements.

Randy Nelson, president of Swisstrax, a manufacturer of workshop and garage floor products, says that garages are quickly evolving into more than simply places where people keep their cars. Installation of the company's special-purpose floor tile in garages and workshops is booming.

"[Spaces for making things] have just about doubled in the last ten years," says Nelson.

"People aren't just stuffing junk in their garages any more. It's become the male domain, the place where they can do their work and have their tools."

There are scores of books providing advice on setting up a wood shop or metal shop, and many others that describe setting up specialty areas such as a paint shop, a photography studio, or a chemistry laboratory.

But what I wanted was not a single-purpose workspace. I was seeking the ultimate, multipurpose maker's workshop: a versatile, flexible space capable of handling nearly any project I could think of—from building a cedar-strip canoe to compounding fuel and oxidizer for a rocket engine, from soldering a Minty

Boost to developing a model ornithopter.

This series of articles details the creation of a modestly sized yet state-of-the-art maker's workshop, which I named the Barrage Garage.

This installment covers the design and construction of my Barrage Garage, and the considerations behind its doors and windows, floor coverings, and other infrastructure. The parts that follow describe the equipment inside it, such as workbenches, machine tools, hand tools, and my own space-saving tool storage system.





## Workshop Design Criteria

» The first step was to determine which features were the most important and practical.

**Egress** A 9-foot-wide, automatic, well-insulated door outfitted with required safety equipment was essential. The huge door makes bringing materials in and out of the workspace a snap.

**Fenestration** Natural light and a view to the outside were high on my list of priorities. Therefore, the design called for four east-facing sliding windows having a total glass area of 24 square feet.

**Organization** I devised a plan for a combination of stackable modular cabinets, which, along with a slotted wall storage system, maximize the efficiency and versatility of my space.

**CUSTOM CAVE:** The obvious advantage of building a workshop from scratch is the luxury of specifying it perfectly to your needs.

**Surfaces** I wanted more functionality and style than a concrete floor could afford. I selected a special-purpose tile floor for workshops and garages that makes walking and standing more comfortable.

**Power** I needed 240 volts to run the heater and welder, and 120-volt receptacles placed at frequent intervals along all walls on two separate 20-amp, GFI-protected circuits. This ensures a plentiful, safe supply of electrical power to all tools.

# Building the Barrage Garage

» My first task was to site the structure. Where should the workshop go?



Initially I considered placing the shop in my basement. Possible, but this would involve far too many compromises. The basement is a low-ceilinged space with marginal access via a narrow stairway. The thought of carrying tools and materials up and down, turning corners, and so forth quickly dissuaded me.

Instead I turned to the nearly forgotten space along the alley in back of my home. Separated from the rest of my yard by a chain-link fence, it was covered with 25-year-old lilac bushes. I loved those fragrant, beautiful spring blossoms, but the space those lilacs grew upon was workshop-perfect: it had room, privacy, and access. So, goodbye lilacs.

City ordinances allowed me a maximum of 240 square feet for the shop. With the city building permit obtained, it was time to push some dirt.

## Pushing Dirt

It all starts with a level floor. Every workshop, atelier, pole barn, or garage must have a level floor if great things are to be made in it. It has always been this way.

Four thousand years ago, in the reign of the great Egyptian pyramid builders, construction techniques were rudimentary. Imhotep, legendary architect of the pharaohs, had only knotted measuring ropes stretched taut between stakes, plumb bobs, and sighting sticks.

But Imhotep gave the pharaohs the tools to build monuments capable of withstanding 50 centuries of desert sandstorms. He did that by starting with a perfectly level floor. It's believed that the Egyptians leveled the area under a pyramid by cutting a shallow grid of trenches into the bedrock, then filling them with water. Knowing that the height of water

within connected trenches would be at exactly the same level, the workers hacked out the intervening islands of stone and sand with hoes and stone drills.

The Barrage Garage has a flat floor as well, but my excavators used a 75-horsepower backhoe and modern surveying tools including transits and lasers. My end result is pretty much the same as Imhotep's: a perfectly level slab placed in exactly the right spot.

## Concrete Ideas

After excavation, the concrete work began. Concrete is composed of Portland cement, gravel, sand, and water. When freshly poured, concrete is wet and plastic. But within hours it begins to solidify, ultimately becoming as hard as rock.

Most people call that process "drying," but the concrete crew foreman on my job told me that's not really the best choice of words. Concrete does not simply solidify because excess water has evaporated from the slurry. Instead, the water reacts with the cement in a chemical process known as hydration. The cement absorbs the water, causing it to harden and bond the sand and pebbles together, creating the stone-hard material we know as concrete.

## Framing the Concept

Prior to the mid-19th century, building was an art that took many years of apprenticeship to learn. There were few, if any, building codes. Quality of work was based largely on the personal integrity and craftsmanship of each builder.

For 2,000 years, the most common technique for building



with wood was the method called *timber framing*. Buildings of that era still exist; typically they are barns and homes with huge wooden beams supporting large open spaces.

In the mid-19th century, building techniques changed. Cheap, factory-produced nails and standardized, “dimensional” lumber from sawmills allowed for a faster, more versatile method of construction called *balloon framing*.

Invented by Augustine Taylor of Chicago, balloon framing revolutionized building construction. It utilized long, vertical framing members called studs that ran from sill to eave, with intermediate floor structures nailed to them. What used to take a crew of experienced timber framers months to join and raise, could be constructed in a fraction of the time by a competent carpenter and a few helpers.

Over time, balloon framing evolved into the current technique known as *platform framing*. The Barrage Garage, like most modern buildings, is built by nailing together standard dimensional lumber—2×4 trusses holding the roof and 2×6 studs forming the walls—at code-defined intervals. Then, plywood sheathing is attached to the lumber frame, and the basic structure is complete.

## A Solid Floor

The first order of business after the workshop shell was complete was to install the floor. There are three general options: coatings, mats, and tile. Each has its own advantages and disadvantages.

Most common and least expensive are coatings. There are several types of coating available for concrete floors, including epoxy, polyurethane, and latex.



**SCRATCH BUILT:** A perfectly level slab is an imperative start. I used platform framing for the structure, and durable, cushioned vinyl tile for the flooring.

Epoxy paint is probably the most widely applied form of floor coating. Epoxy forms a hard, durable surface and bonds solidly to a correctly prepared surface. Because floor coating provides no cushioning, it can be hard on feet and legs. Also, it doesn't last forever: expect to recoat the floor every five years or so.

Polyurethane coatings are also very durable, and they resist chemical spills better than epoxy. But urethanes do not bond directly to concrete, so an epoxy primer coat is required.

Latex garage paint is widely available and inexpensive. It goes on easily and doesn't require the prep work associated with epoxies and urethanes. However, it's less durable.

PVC floor protection mats are another option. They protect the porous concrete floor from staining or corrosive chemicals such as oil, paint, or acid. Mats are typically simple to install, requiring only scissors. Importantly, they add a cushioning layer above the hard concrete.

Special-purpose vinyl tile is

the premier flooring option for workshops and garages, and that's what I installed in the Barage Garage. These floor tiles, from Swisstrax ([swisstrax.com](http://swisstrax.com)), snapped together firmly and were installed without special tools.

Tile handles heavy loads and high traffic. It resists damage caused by chemicals, and it's far more comfortable to stand on than concrete. But best of all is tile's ability to transform a humdrum workshop into a great-looking space.

## Choose Your Tools

Outfitting the all-purpose maker's workshop with the tools to tackle most any project.

By William Gurstelle



Photography by William Gurstelle

So far, I've detailed the construction of my all-purpose maker-style workshop, which I've nicknamed the Barrage Garage. It's turned out beautifully, and as anticipated, it's the envy of my maker friends.



Small? Sure, it's a mere 20 feet by 14 feet, but it has all the space required to do serious creating. It's loaded with features, including a way-cool vinyl tile floor, a high-tech wall storage system, fluorescent lighting, 240-volt power, and lots of electrical outlets.

After the infrastructure was completed, it was time to outfit the Barrage Garage. Choosing tools and supplies is a subjective question to be sure, and one that a dozen people would answer a dozen different ways. My goal was to make the Barrage Garage into the Platte River of workshops: a mile wide and three feet deep. Like the Platte, my workshop covers a lot of different areas but is not particularly deep in any single genre. Flexible as a yoga instructor, it provides an environment in which I can attempt projects in wood, metal, chemistry, home repair, electricity, even the odd bit of pyrotechnics (see *MAKE Volume 13, page 54*).

If you're a maker with dreams of metalworking, woodworking, building electronics projects, customizing your rod, or simply keeping your house up and running, read on. In this installment, we'll examine the must-have tools and equipment that make the Barrage Garage such a maker-enabling space.

## The Workbench

Building a workbench was my first consideration, for it's literally the foundation on which all subsequent work will be built. I considered the design carefully, evaluating possibilities ranging from a complex Scandinavian design with a beechwood frame mounted on self-leveling hydraulic cylinders, to an interior door nailed to two sawhorses. I chose something in the middle—a solid, heavy, counterbraced construction made from 2×6 fir lumber.

The work surface is two-thirds wood and one-third granite. From a local countertop maker I was able to inexpensively obtain a beautiful 2'×2' piece of polished granite left over from a bigger job. The ultraflat, smooth granite is perfect for doing fine work or electrical projects. The plywood-covered 2×6s are great for everything else.

I finished the workbench by outfitting it with a wood vise with bench dogs (wooden inserts mounted opposite the vise to hold oversized work pieces), a portable machinist's vise, and a pullout shelf.

The typical advice from experts to novices is to buy the best quality tools you can afford. And I believe it's good advice. Cheap screwdrivers, for example, can be a big mistake; the soft metal

**FUN STARTS HERE:** With your workshop structure built, the next step is choosing the tools and workbench setup best suited to your projects. I chose a sturdy, counterbraced fir bench and a wide array of basic tools.

edges of inferior blades can bend or even break under stress, and the plastic handles chip when dropped. For any tool you use frequently, it makes sense to go with quality.

On the other hand, when you've got a one-off job, and you're not sure if you'll ever have another application for piston-ring pliers or a gantry crane, then buying an inexpensive tool may make sense.

Besides raw materials and tools, I stocked up on general supplies: duct tape, electrical tape, transparent tape, powdered graphite, rope or cord, twine, light oil, white glue, super glue, quick-set epoxy, extended-set epoxy, sandpaper, heat-shrink tubing, zip ties, pencils, ink markers, rags, wipes, and towels. Now, on to the tools.



# The Tools

## BASIC TOOLS

**A. Electric drill, cordless or corded** A drill with a variety of screwdriver tips and drill bits may well be your most frequently used power tool. In the Barrage Garage, where I have power outlets everywhere, I appreciate the lightness and torque of a corded drill. But many people appreciate the flexibility of a cordless model. The higher the top voltage (e.g., 14.4 or 18 volts) of a cordless drill, the greater its torque and the more it weighs.

**B. Files and brushes** Flat and round bastard files and a wire brush. (A bastard file refers to one with an intermediate tooth size.)

**C. Cutters** You'll want diagonal cutters, a utility knife, tinsnips, a wire cutter/crimper/stripper, and a good pair of scissors. You'll find a self-healing cutting mat to be a great help; buy one at any fabric store.

**D. Mixing and volume-measuring equipment** Sturdy plastic bowls in different sizes, disposable spoons, measuring cups, and measuring spoons.

**E. Hacksaw** For those occasions that require cutting through something harder than wood.

**F. Handsaw** Most often, you'll likely be cutting dimensional lumber (2×4s, 2×6s, etc.) to size, so choose a saw with crosscut teeth instead of ripping teeth.

**G. Linear measuring gear** Tape measure, protractor, and combination square.

**H. Socket and wrench set** If you work on things mechanical, you'll appreciate the quality of a good socket set. Spend the money and get English and metric sockets, as well as Allen wrenches (hex keys).

**I. Pliers** come in a variety of shapes. At a minimum, you should have standard, needlenose, and vise-grips.

**J. Hammers** Start with a claw hammer for nailing and a rubber mallet for knocking things apart.

**K. Digital multimeter** If you do any electronics work, a volt-ohm meter with several types of probes and clips will be indispensable.

**L. Screwdrivers** Choose an assortment of high-quality Phillips and flat-headed (and possibly Torx) screwdrivers in a variety of sizes.

**M. Scale** A triple beam balance or electronic scale is a necessity for chemistry projects and mixing stuff.

## POWER TOOLS

### N. Belt sander

**O. Drill press** I simply can't live without my drill press, because it provides far more accuracy than a hand drill ever could.

### P. Cut-off saw

### Q. Grinder

Beyond these basics, there are hundreds, if not thousands, of tools available, all of which may be useful depending on the project. In regard to stationary power tools, it's a tough call. Because they're expensive and require a lot of shop real estate, it really depends on what you're going to do *most*. I use my table saw all the time. But I know people who consider a band saw an absolute necessity and others who say a scroll saw is their number one power saw priority.

## SPECIAL TOOLS

**Soldering iron** Choose a variable-temperature model with changeable tips.

**Magnifying lens** You'll find a swing-arm magnifier with a light a very helpful addition to your shop. It mounts directly to your workbench and swings out of the way when not in use. It's great for everything from threading needles to examining surface finishes.

**Safety equipment** Safety glasses, hearing protection, a fire extinguisher, goggles, a dust mask, and gloves are very important.

All safety glasses, even inexpensive ones, must conform to government regulations, so they all provide adequate protection. However, more expensive ones are more comfortable and look better, making you more inclined to always use them.

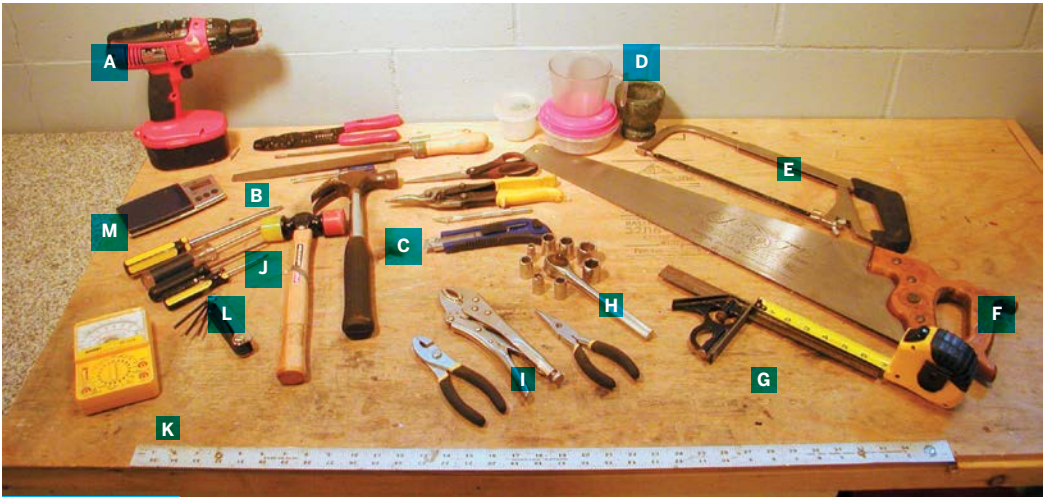

Basic Tools



Power Tools



Safety Equipment



General Supplies

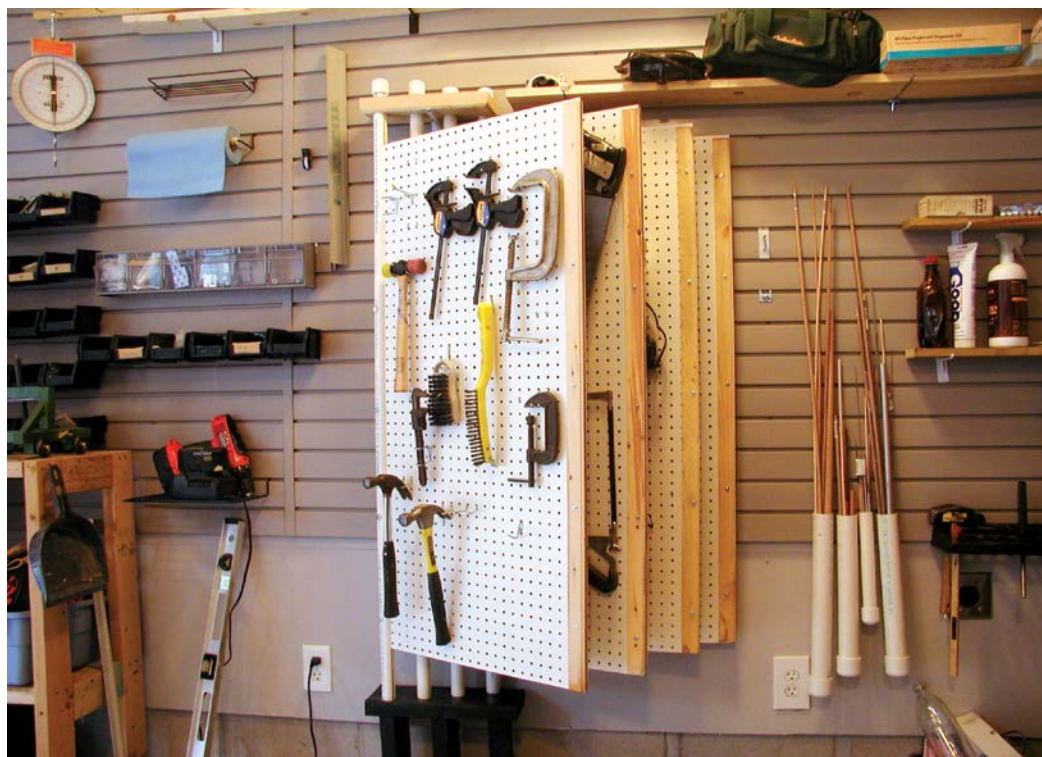

## The Tool-Zine

OK, once you've got all this stuff, where are you going to store it? I use a combination of bins hung on StoreWall ([storewall.com](http://storewall.com)) panels, and my own contrivance that I call the Tool-Zine. It's easy to build and provides an incredible amount of storage in a small area.

The Tool-Zine is like a magazine for tools; you store your tools on "pages" and simply turn to the correct page when you need a particular tool. You'll be amazed at the convenience and organization it brings to your shop.

A 4-page Tool-Zine provides the equivalent of 64ft<sup>2</sup> of wall space in a space slightly larger than 8ft<sup>2</sup>. That's a highly leveraged storage solution!

Conceptually, the Tool-Zine is straightforward. It consists of four 1" PVC pipes slotted lengthwise. A 2'x4' piece of 3/8" pegboard is inserted into each slot and fastened with machine screws. Next, wood lath is bolted to both sides of the pegboard to make it rigid. This

entire assembly makes a single page of the Tool-Zine.

Four pages are assembled and then mounted vertically on wooden brackets that are firmly affixed to wall studs, reminiscent of the way the pages in this magazine are bound to the spine.

### MATERIALS

- » **1" Schedule 40 PVC pipes (4)**  
5' long
- » **1" PVC pipe end caps (4)**
- » **1" wood laths, 4' long (4)**
- » **3/8" pegboard in 2'x4' sections (4)** Other pegboard thicknesses might work, but you'll have to adjust the slot width.
- » **2x6 lumber** about 8' long
- » **1/4" machine screws, 1 1/2" long (20)** with nuts and washers
- » **#8 machine screws, 1 1/2" long (20)** with nuts and washers
- » **Wall anchors** or wood screws

Illustrations by Tim Lillis

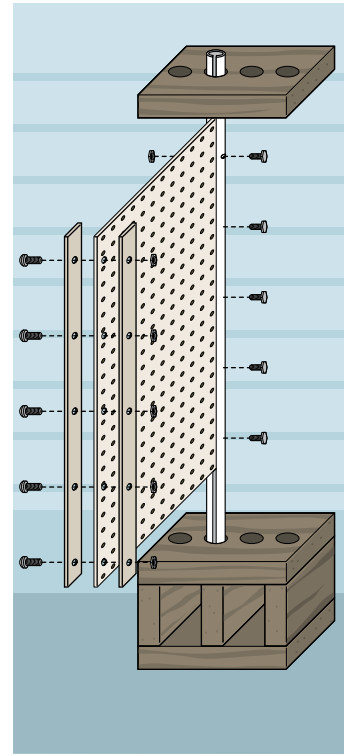
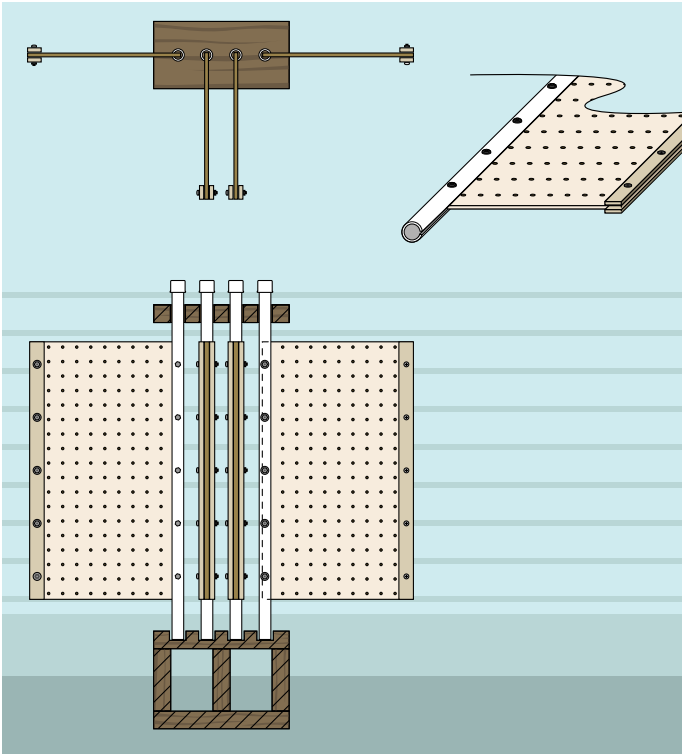

## Make Your Tool-Zine

The diagram shown here has all the information you need to build the Tool-Zine. Here are a few pointers to make the task easier.

**1.** The most difficult part is making the long slot in the PVC pipe. To fit the pegboard, it must be straight, with a constant width. You will likely need a table saw to do this successfully. I bolted the PVC to a 2×2 piece of dimensional lumber so I could use the saw's rip fence to keep the cut as straight as possible.

**2.** Set the saw blade height on your table saw so that it's just high enough to cut through the bottom of the PVC, but doesn't cut into the bolts used to attach the PVC to the 2×2 guide piece.

**3.** Depending on the kerf width of your saw's blade, it may be difficult to slide the pegboard into

the slot. If so, use a rubber mallet to pound it in.

**4.** Be sure to anchor the top bracket firmly into the wall studs.

**5.** I chose to build a platform to support the lower bracket. The platform rests on the concrete floor and is attached with a concrete anchor. As an alternative, the bottom bracket could be wall-mounted like the top bracket. If you do this, make sure the brackets are securely mounted to structural members that can handle the weight of your tools.

**6.** The Tool-Zine is customizable. You can easily add additional pages or increase the distance between pages by extending the size of the brackets. However, if you do, be sure the brackets are adequately anchored to the wall studs.

**COMPACT YOUR COLLECTION:**  
Easily flip through your tools with this customizable organizer made of pegboard and PVC.



# Stock Your Shop

Be ready with a basic inventory of the stuff dreams are made of.

By William Gurstelle

In my Barrage Garage workshop, I keep frequently used materials on hand at all times. Stocking a well-considered selection of materials is important when I need to make a simple model or a fast prototype to bring an idea to life, or at least prove to myself that it's worth further exploration.

Choosing materials is an important part of any project. But trade-offs abound and it can be tricky to decide which raw material is right for the job. One material may be strong, but difficult to machine. Another may be great for use indoors but lose its integrity when placed in the elements.

Over time, I've developed an inventory of basic raw materials that enable me to start, and sometimes even complete, a great variety of projects without the need to visit a lumberyard or wait for the UPS truck.

## Dimensional Lumber

Dimensional lumber is the wood commonly sold in lumberyards. It's sized according to standardized widths and depths that are nominally described in whole numbers, but its actual size is  $\frac{1}{4}$ " or  $\frac{1}{2}$ " less than described. For example, a 1x2 board is actually  $\frac{3}{4}$ "x1 $\frac{1}{2}$ ".

Dimensional lumber comes from softwoods like fir and pine. Cut into 2x4s, it's commonly used for building the frame or supporting structure of a project. Shelves and smaller objects are frequently made from 1"-thick

(nominal) boards of various widths and lengths.

It's inexpensive and versatile, so keep ample supplies on hand for spur-of-the-moment projects.

I like to stock:

**1x2x8' (4)**

**1x4x8' (4)**

**2x4x8' (4)**

## Engineered Wood

Engineered wood products are manufactured from wood components and adhesive. Strong and light, they're just the thing for covering walls and roofs, and they're useful for projects of all types. Engineered woods include the old standby, plywood, as well as particleboard and medium-density fiberboard (MDF).

MDF and particleboard are manufactured from wood pulp and glue pressed into sheets. They're easy to cut and sand, a plus for the inexperienced maker. They're cheaper than plywood, and not as prone to warping.

Plywood, on the other hand, is proportionally lighter and stronger than MDF and particleboard. It holds fasteners more securely, and has far better moisture resistance. Plywood comes in a variety

of thicknesses;  $\frac{3}{8}$ " and  $\frac{5}{8}$ " are the most commonly used.

Engineered wood comes in 4'x8' sheets that can take up a lot of storage space. If that's a problem, cut the sheets in half. Stock:  **$\frac{5}{8}$ " plywood, B or C grade, 4'x4' sheets (2) or a 4'x8' sheet** if you have room

## Dowels

When dimensional lumber is too big, dowels (cylindrical rods made from solid wood) are utilitarian wonders. They're great for aligning, fastening, and supporting project parts. Stock:

**$\frac{1}{4}$ " dowel, 3' lengths (4)**

**$\frac{3}{8}$ " dowel, 3' lengths (4)**

**$\frac{1}{2}$ " dowel, 3' lengths (2)**

## Hardware Cloth and Expanded Metal

Hardware cloth is wonderfully useful stuff. It's a sheet of stiff, galvanized steel wire welded into a regular square mesh. Flexible and strong, it's perfect for screening off large areas inexpensively.

Expanded metal is a rigid, open mesh made from sheet metal that has been slit and expanded. It is much stronger and more rigid





**MATERIAL WORLD:** Having a well-stocked selection of basic materials makes it possible to build (and photograph) on the fly.

than hardware cloth.

You can use these materials for animal-proofing, providing support for materials such as plaster or concrete, making guards for dangerous areas, and more. Expanded metal is strong enough to be walked upon. Stock:

**Hardware cloth, ¼" mesh, 2'×4' sheet (1)**

**Expanded metal, 2'×4" sheet (1)**

### Angle Iron aka Structural Steel

Structural steel or iron, like dimensional lumber, is most often used to build a frame or superstructure. The many types of structural steel are described by the shapes they make when looking at them on-end—angles, channels, bars, I-beams, and more. Angle iron is the king. It's relatively inexpensive, extremely strong, and can be attached to other pieces of iron by fasteners or by welding.

I keep several 8' pieces of galvanized 14-gauge slotted angle iron on hand. Although its galvanized surface makes it nearly unweldable, it's still wonderfully versatile. The slots allow pieces to be cut and joined easily using ¾" bolts and nuts. Channels and I-beams are useful in situations requiring greater stiffness, although they're

heavier and cost more per linear foot. Stock:

**Slotted steel angle, 1¼"×1¼"×8' (2)**

### Brass Sheet

Brass is an alloy of copper and zinc. Stronger than copper alone, brass sheet is a great prototyping material that can be machined, bent, or cut to close tolerances. It's easily worked with common hand tools and can be joined by soldering or by mechanical fasteners. Stock:

**Brass sheet, .032"×6"×12" (1)**

**Brass sheet, .016"×6"×12" (1)**

### Plastic Pipe and Pipe Fittings

Because of its low cost, strength, and easy workability, PVC (polyvinyl chloride) is among the most common plastics in use. PVC pipe comes in many sizes and shapes, with many types of connectors (called fittings). It's useful for making furniture frames, medium-duty support structures, and plumbing for liquids or air. Stock:

**PVC pipe, 1" diameter, 8' lengths (2) with 1" elbows (4), tees (4) and caps (4)**

**PVC pipe, 2" diameter, 8' lengths (2) with 2" elbows (4), tees (4) and caps (4)**

### Music Wire

Beloved by makers for its ability to be bent and then retain its shape, this tough and springy wire is especially useful in making mechanisms and models. Be forewarned, it's really tough stuff, requiring a special cutter (or a high-speed rotary tool like a Dremel). Stock:

**Music wire, .056" OD, 3' lengths (2)**

### Fasteners

Nearly all projects involve joining parts together, commonly by using mechanical fasteners such as bolts, screws, and nails. Going to the hardware store for every nut and bolt consumes time and fuel, so keep a reasonable selection of fasteners on hand. Stock:

**Round-head or pan-head machine screws (12 each):**

**4-40×¼"**

**4-40×½"**

**6-32×⅜"**

**6-32×¾"**

**8-32×½"**

**8-32×1"**

**10-24×½"**

**10-24×1"**

**¼-20×¾"**

**¼-20×1"**

**Hex-head cap screws (6 each):**

**¼-20×1½"**

**¼-20×2"**

**⅜-16×1"**

**⅜-16×1½"**

**⅜-16×2"**

**⅜-16×2½"**

**Nuts (24 each):**

**4-40**

**6-32**

**8-32**

**10-24**

**¼-20**

**⅜-16**

**Nails (1 box each): 2d and 8d**

# THE SAFE WORKSHOP

## Rules to make by.

By William Gurstelle

Your workshop should be a welcoming and friendly place. The key lies in creating a safe and secure environment. Before embarking on a new project, it's a good idea to take a close look at the working conditions in your shop.

If your project area gives you a vaguely nervous feeling, then now's the time to bring things up to date. Don't delay — inspect, review, and evaluate your space and make whatever changes seem necessary to keep you out of trouble.

Don't know where to start? Here are some ideas from the members of MAKE's Technical Advisory Board to get you started. Have at it!



Photography by Jason Madara

DIY

## WORKSHOP

HERE'S THE ESCAPEE:  
A 0-80 nonmagnetic  
stainless steel  
socket-head cap screw.

# LOST SCREW FINDER



An easy vacuum attachment that filters small nonmagnetic parts. By Frank Ford

### MATERIALS

Plastic CD-ROM spindle container

**Finally, a use for one of these!**

Small wire screen I cut mine from an old kitchen strainer.

1" diameter PVC plumbing: two 90° elbows, one 45° elbow, and 2' of pipe

Silicone glue

A vacuum, plus any adapter needed to fit it to the PVC My shop vacuum's 1½" hose fit the PVC pipe after a bit of filing, no adapter necessary.

### TOOLS

Hacksaw or PVC pipe cutter

Utility knife

Metal file

Scissors or wire cutter

Stapler or stapler gun

Ever drop a screw or other teeny part, look around like crazy, and finally have to give up? Wish you had a magic magnet that could attract plastic or brass parts out of the debris on your shop floor?

Well, that's never happened to me ... but if it ever does, I'll be glad I made this little gizmo. It's a vacuum attachment that captures small bits in a little canister so I can sort through them.

**1.** Using a knife along with a short piece of PVC pipe as a template, mark and cut 2 holes in the base of the CD spindle. Neatness doesn't count for much here, but the holes should just clear the diameter of the pipe and shouldn't be too irregular.

**2.** Cut ¼" sections off 1 end of each of the 90° elbows. Again, accuracy isn't important. My



**Fig. A:** Fit the inlet pipe through one of the holes in the plastic spindle base, and secure it on the inside with more adhesive. **Fig. B:** Fashion a little screen “boot” that slips over the end of the outlet pipe.

**Fig. C:** Glue a 2" section of pipe into the inlet elbow, and glue the 45° joint onto the other end, angled back down toward the spindle base. **Fig. D:** Screw the CD spindle-cover canister into place.

weapon of choice is a hacksaw, but any saw or pipe cutter will do.

**3.** Using a file, taper the uncut end of one 90° elbow so that it fits the hose of your vacuum or attachment. This is your outlet elbow. My vacuum takes a 1½" input, but your mileage may vary, so here's where you'll improvise.

**4.** Cut a ¾" section of pipe and squidge on a bunch of silicone glue as you fit it into the cut end of the second 90° elbow. Fit the pipe through one of the holes in the plastic spindle base, and secure it on the inside with more adhesive and the ¼" ring you cut off. This is the inlet pipe (Figure A).

**5.** Make your outlet pipe the same way, but use a 1½" section of pipe. It should stick in 1" or so into the CD spindle base.

**6.** Fashion a little screen “boot” that slips over the end of the outlet pipe (Figure B). I hacked away at my screen with scissors, and trial-fit the shape onto a spare piece of pipe. When I got a form that worked, I stapled around the form to hold the shape in place.

**7.** Glue the screen boot onto the end of the outlet pipe with a lot of that silicone goo, and use more to seal up its ragged edges.

**8.** Glue a 2" section of pipe into the inlet elbow, and glue the 45° joint onto the other end, angled back down toward the spindle base (Figure C). Fit in a longer section of pipe, to serve as the nozzle. I didn't glue this last section, so that I could switch to different lengths as needed.

**9.** Screw the spindle-cover canister into place (Figure D), and it's ready for use!

## Putting It to Use

Using the Lost Screw Finder is a simple affair. Sweep the area where the errant part was last suspected, round up everything, and check the contents of the dragnet. Most suspects stick to the screen, right where you'd expect them.

---

Frank Ford is a founder of Gryphon Stringed Instruments in Palo Alto, Calif., where he has been a full-time luthier since 1969. He's a prolific writer, appearing in books, magazines, and his website, [frets.com](http://frets.com).





# MINI FUME EXTRACTOR



Candy tin device helps keep your air clean and your lungs healthy. By Marc de Vinck

A fume extractor uses an activated carbon filter and fan to remove the smoke, and noxious fumes, created from soldering. The average price of a small hobby version is about \$100, but this one will run you more like \$10. This mini fume extractor won't be as effective as a larger one, but it's definitely better than nothing, and extremely portable. Remember, always work in a well-ventilated area.

### 1. Build the circuit.

I decided a quick mock-up might be a good idea, and I'm glad I did. At first, I thought that running the case fan off just one 9-volt battery would provide adequate power. In the end I decided that 12 volts "sucked" better, and in this case that's a good thing.

The final circuit (at right) uses a simple switch, two 9-volt batteries, a 40mm case fan, and a 7812

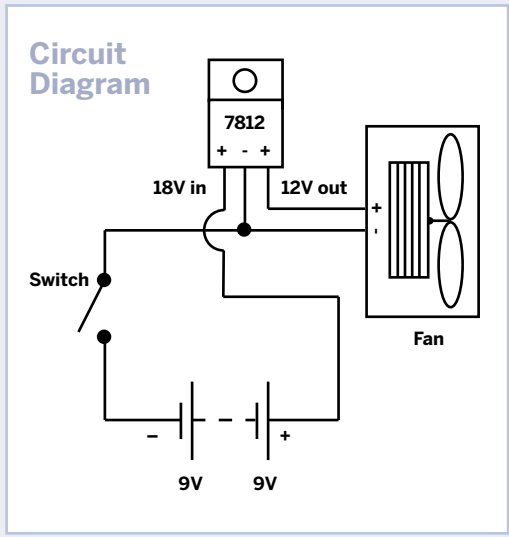

Photography by Marc de Vinck

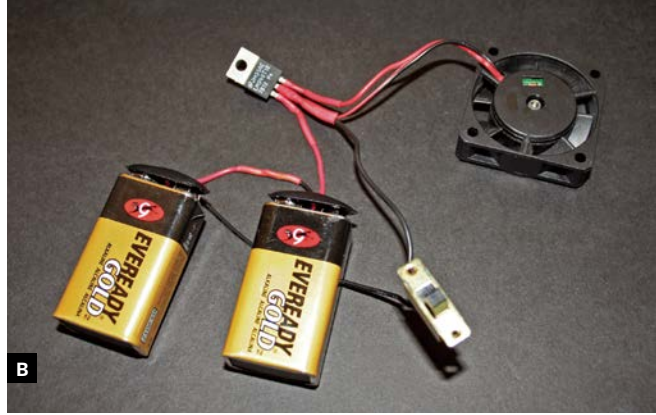
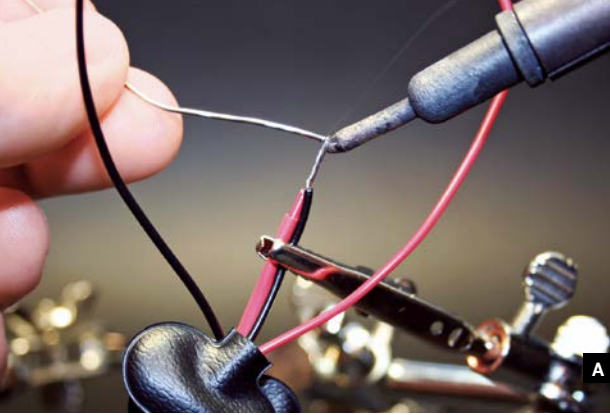

Fig. A: Vinyl 9-volt connectors are low-profile enough to let everything fit. Fig. B: The completed circuit. Make sure to orient the 7812 according to the schematic, and don't forget to slip on heat-shrink tubing prior to

soldering, to insulate all connections from the conductive metal tin. Fig. C: It's a snug fit. Fig. D: Use light pressure when cutting the openings; let the tool do the work. The openings don't have to be perfectly aligned.

### MATERIALS

- 7812 voltage regulator IC
- Candy tin
- Switch, SPST (single pole, single throw)
- Case fan, 40mm square
- 9-volt batteries (2)
- 9V battery connectors (2) **vinyl, not hard plastic**
- Pieces of screen, 50mm square (2)
- Piece of carbon filter **cut from a replacement filter**
- Heat-shrink tubing
- Insulated, threaded hook-up wire
- Miscellaneous screws and washers
- Paint (optional)

### TOOLS

- Soldering iron
- Rosin-core solder
- Dremel with cutoff wheel
- Drill and small drill bits
- Fine-tip marker
- Various screwdrivers
- Wire cutters
- Safety glasses

**⚠ CAUTION: Wear safety glasses when drilling and cutting metal!**

voltage regulator. The 7812 takes voltage from the 9V batteries wired in series and steps the voltage down from 18V to 12V, which is what the fan requires.

## 2. Solder the components.

Notice the battery connectors (Figure A); they're the flexible vinyl version, not the hard plastic type. This allows both batteries to fit in the case. The vinyl snaps are only minimally smaller, but it's enough to make the difference.

This is a very simple circuit. Solder it according to the diagram, making sure to attach the component leads to the 7812 properly (Figure B). Don't forget to use heat-shrink tubing on all connections; this is in a metal box ... and metal conducts electricity!

## 3. Make sure it all fits.

It's a snug fit, but you should be able to stuff everything into the tin, packing the batteries side by side next to the fan (Figure C).

## 4. Cut and drill the holes.

I used a marker and a paper template for the fan openings, making them 35mm square on each side. After you cut the first fan hole, close the box and



E

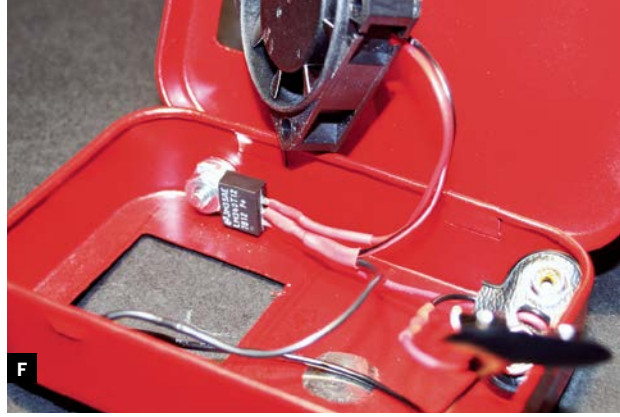

F



G



H

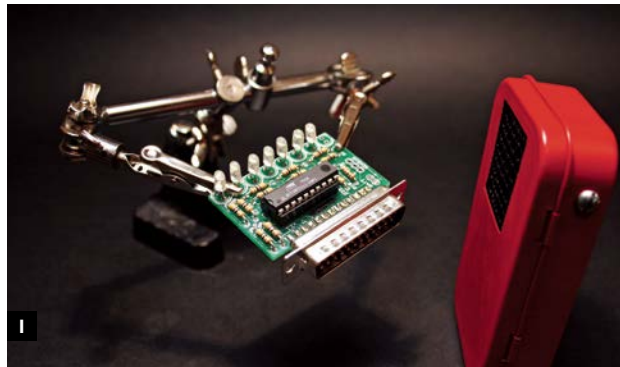

I

Fig. E: Mount the tin to a wooden stick with hot glue. It can easily be removed, and your hands won't get all red! Fig. F: Attach the 7812 and the switch with a few screws. Fig. G: Screen, filter, fan, and screen make

a nice little sandwich. Fig. H: All ready for your next soldering project. Fig. I: It works great, it's highly portable, and your lungs will thank you.

use the template to align the second hole. You can just "eyeball" the placement. There's room for error.

Then I marked the opening for the switch and cut all openings with a Dremel tool and cutoff wheel (Figure D).

Next I marked and drilled 2 mounting holes for the switch screws and one for the regulator.

## 5. Paint and decorate.

I decided to paint the tin this time, unlike my plain RuntyBoost ([makezine.com/2008/03/22/making-the-runtyboost](http://makezine.com/2008/03/22/making-the-runtyboost)). I chose a nice red Krylon paint. I hot-glued a scrap piece of wood to the inside, so I could hold it while I spray-painted it. Two quick coats and I think it looks good (Figure E). Spray paint can be fairly toxic and flammable, so paint outside and away from everything! I'm happy with how it came out, but it definitely needs some graphics to spruce it up. Any suggestions?

## 6. Attach the regulator and switch.

First, screw in the 7812 using some washers and a screw to space it slightly away from the side of the tin (Figure F). I used a #6-32 screw and one washer

to keep it from the edge, but you can use anything that fits. The screws and washer will also act as a heat sink.

Finally, screw in the switch.

## 7. Add the screens and filter.

Here you can see the screen-filter-fan-screen sandwich (Figure G). The screens are 50mm square and the filter is 40mm square. You can buy replacement filters for the commercial extractors at a reasonable price and cut them to size.

Next, just hot-glue or epoxy the corners of the screens to the candy tin, and sandwich the filter and fan in between (Figure H). Compression will ultimately hold it all together. You're done!

## 8. Test your extractor.

I've run mine continuously for hours and have had no heat buildup from the 7812, and the fan is still running strong (Figure I). It works quite well, and although it's no replacement for a large fume extractor, it will come in handy for small projects. Remember, follow all safety guidelines when soldering, and work in a well-ventilated room, even if you have a fume extractor.



# SKILL BUILDER+

Learning new tricks every issue

EASY

## UNDERSTANDING

# BASIC WOODWORKING TOOLS

Ten simple hand tools for building almost anything

Written by Len Cullum



### LEN CULLUM

is a woodworker living in Seattle, where he specializes in building Japanese-style garden structures and architectural elements.

When not woodworking, he teaches at Pratt Fine Arts Center, writes, and dreams of a robot that would sharpen his chisels.

I'm going to focus on what I consider the six basic hand tools for working with wood, plus my four go-to tools for measuring. These are the fundamentals that will allow you to build most anything. Keep in mind that no one tool is right for everyone. The hammer that I love might be the one that makes your wrist sore, or my favorite saw might feel backward. Don't be afraid to try different tools and techniques until you find the ones that feel right and make the most sense to you.



## TIP

A tip for claw hammer users: When doing lighter chopping, try using the side of the hammer head to drive the chisel instead of the face. It gives you more control and a larger striking area.

## THE HAMMER

Nothing says blunt force like a hunk of metal on the end of a stick.

It's probably the oldest tool in the book. When I first started woodworking, I remember seeing a picture of a guy with his hammer collection, it was a whole room filled with hundreds of different hammers. At the time, I couldn't imagine needing more than one, but I feel much differently now.

Within eyeshot as I type this, I can see nine hammers. Each is different and each sees (fairly) regular use. The one pictured below is easily my favorite. It's a 375g Japanese carpenter's hammer. One face is flat, for driving nails, the other is slightly convex for driving the nail below the surface. I use it for everything from driving chisels and adjusting planes to knocking joints together and closing cans. It's my go-to hammer. The weight is right, and I like its balance.

If your work will require a lot of nailing, a claw hammer might be a better choice. Personally, I would just add a small pry bar to my collection.



Len Cullum

## CHISELS

Chisels can be used for anything from heavy chopping to light paring or fine carving. While also known to open paint cans, turn screws, and act as a pry bar, these are not recommended uses. Seriously, use a screwdriver. A screwdriver will appreciate the attention. While there are hundreds of chisel sizes and styles, most people can get by with four:  $\frac{1}{4}$ ",  $\frac{1}{2}$ ",  $\frac{3}{4}$ ", and 1" standard bench chisels.

There are virtually no chisels that are ready to use right off the shelf; they all need some sharpening to get them to sing. Once you experience a truly sharp chisel, you will understand the difference, not only by what you're able to achieve, but the ease with which you can do it. Below is a heavy patterned chisel called *atsu-nomi* (thick chisel) that's used for cutting joints in large timbers. It's part of a set made for me by master blacksmith Iyoro, and it's one of my favorites.



## HAND PLANES

Historically, hand planes were used mostly (but not exclusively) for smoothing and adjusting the thickness of rough board (called "thicknessing"). These days most stock dimensioning is done by machines, but this doesn't mean the hand plane is obsolete. It remains an incredibly useful tool that no woodworker should be without.

A well-tuned plane can do in minutes what can take a sander an hour, and produce an arguably better surface in the process — allowing you to work while standing in a pile of shavings instead of a cloud of dust. If I had to choose only one, it would be a low-angle block plane, pictured below. It can be used for everything from trimming and shaping stock to finish-planing surfaces. Like chisels, they're rarely ready to use out of the box and need to be sharpened before use.



### HANDSAW

As with the hand plane, much of the work a handsaw performs has been picked up by the powered version. Even so, the handsaw remains a useful and necessary part of a woodworker's collection. For cutting wood, there are two basic types: rip saws and crosscut saws.

Rip saws are meant to cut in the direction of the grain and typically have fewer, bigger teeth. Crosscut saws are, as the name implies, for cutting across the grain. They typically have more and finer teeth in order to shear the grain and leave a cleaner cut.

While general-purpose and combination saws exist, they tend to be a little too aggressive for careful work. My choice of handsaw is a Japanese *ryoba nokogiri* (double blade saw), shown above. It has rip teeth on one side, crosscut teeth on the other, and unlike Western saws, it cuts on the pull stroke. While they used to be difficult to find, you can now usually get them at home stores.

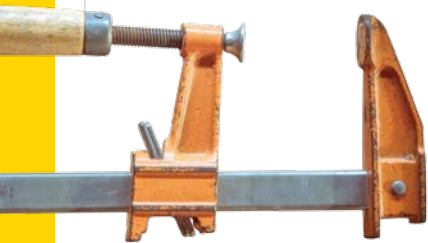

### CLAMPS

Without clamps, nearly every operation with the preceding tools becomes more difficult. Not only are they good for holding together the final assembly, their ability to keep things here you want them while you work is invaluable. There is little that is more frustrating than trying to work a piece of wood that keeps sliding around. A couple of clamps, are essential and most woodworkers, at least once in their life, have repeated the mantra "you can never have enough clamps." Two 24" bar clamps, like the one shown below, are good. Four are better. Eight are better still ...

### WOODWORKING PROJECT LAYOUT TOOLS

Accurate layout work is the critical first step to a successful project. Without precise, repeatable marks, it is very difficult to get everything to come together at the end. So now I'll go over some of the basic tools for measuring, marking, and transferring lines. My big three (actually four) tools for almost all of the work I do are the tape measure, a high-quality 12" combination square, a .005 drafting pen, and a 4" combination square for smaller work.

### MEASURING LENGTH

The three most common measuring devices you're likely to find in a wood shop are the tape measure, folding rule, and steel rule. All three have their good and bad points. But as with all tools, find the one(s) that fit your style and make the most sense to you and the way you work.

The familiar tape measure with its spring-steel blade rolled up into a small box is fast and can measure distances that would require a massive folding rule. On the down side, the little hook at the end of the tape can introduce inaccuracy. When new, the hook slides on rivets just enough to adjust for the thickness of the hook's metal. When measuring to the inside of something, the hook is pressed in; when on the outside, the hook is pulled out, keeping the measurements accurate. This works great for a while, but over time, the holes and rivets can wear and get bigger, or the hook can be bent when the tape measure is dropped. To remedy this, most woodworkers "burn an inch." This is where you ignore the hook and start all of your measurements from the 1" mark. This works well and gives accurate results, as long as you remember to subtract 1" from your result. Trust me, no one who uses this method hasn't had a moment of dread after discovering something (or worse, multiple things) didn't fit to the tune of one extra inch. So stay awake out there.



When choosing a tape measure, consider the type of work you are doing. If you primarily work with material shorter than 12 feet, don't buy a 25-foot tape. Those last 13 feet will never see daylight and the extra mass is heavy and cumbersome.

The folding rule (above) overcomes the hook problem by having a fixed metal cap at the end of its wooden rule. This makes for worry-free use, especially when measuring against something. It also has a nifty little sliding rule built into the end to measure depths and interior distances. On the downside, the thickness of the wooden blade means it must be laid on its edge to get accurate results and the way it folds creates a stair step shape that can make it awkward to use over distances.

The steel rule (at left) is a nice balance between the folder's consistency and the tape measure's small size, but its limitations are obvious. It's great for smaller work, but once you get beyond the 6" mark, one of the above will have to take over.

Honorable mention goes to the story pole or story stick. This is usually a long piece of wood that one puts their own marks on for transferring measurements. This can be more reliable because it gets rid of those numbers, and every distance is as marked. Story poles are very useful when you're measuring larger projects with multiple components (like a kitchen or

library) or when you need to transfer the same dimension over many parts. It helps eliminate measuring mistakes.

## SQUARES

For layout work, a square's primary function is to draw lines 90° perpendicular to a side. As always, there are a few types available but what sets them apart is what else they do. For me, a combination square (at right) is the most useful. Not only does it give me 90° and the occasional 45°, it also transfers measurements from one piece to another, finds the true center of a board, and checks depths and helps set up tools. It's hard to imagine woodworking without it. Definitely spend up when buying one. Get the best one you can afford. A loose, out of square or hard to move blade creates more frustration than it's worth.

The speed square is handy as well, but it is more suited to carpentry. I find the deeply stamped numbers to make for jaggy lines, so I use it mostly for rough layout

and marking.

The *sashigane* is the standard square for Japanese joinery. It looks like a Western framing square but has a much thinner, flexible blade. And also like the framing square, it is covered in mysterious, oddly spaced numbers and strange markings that when in the right hands can be used to figure and lay out some pretty complicated joints. Since I have yet to decipher one, those hands are not mine. ❌



## BUILD THESE SIMPLE WOODWORKING PROJECTS BY LEN CULLUM

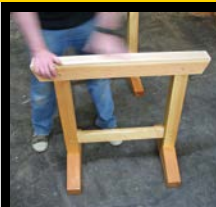

### WORKHORSES

Use a simple mortise-and-tenon joint to make these fine-looking shop horses that'll last a lifetime.

[makezine.com/projects/workhorses](http://makezine.com/projects/workhorses)



### SALT AND PEPPER WELL

So much more elegant than the usual cardboard shakers in your picnic basket.

[makezine.com/projects/salt-and-pepper-well](http://makezine.com/projects/salt-and-pepper-well)



### JAPANESE TOOLBOX

With its clever lift-out lid, this strong wood box carries my tools to nearly every big job.

[makezine.com/projects/japanese-toolbox](http://makezine.com/projects/japanese-toolbox)



## TOOLS & MATERIALS

» **Table saw, chop saw with 12" cut capacity, and handsaw**

» **Drill**

» **Drill bits,  $\frac{7}{64}$  or  $\frac{3}{32}$ , and countersink, or #6 counterbore** I used a Makita #784815.

» **Acid brush**

» **Tape measure**

» **Adjustable square**

» **Small clamps, 2 or more** I used two 6" and four 12".

» **Low horses** optional but helpful

» **Wood, pine or cedar: 1x12 (4') and 1x8 (8')**

» **Screws or nail equivalent:  $1\frac{5}{8}$ " trim-head (36),  $1\frac{1}{4}$ " (16)**

I used drywall screws.

» **Wood glue**

## NOTES

As with all woodworking projects, there are many ways to accomplish the same task. The tools and techniques I show here should be viewed as one option, not the only way. Use whatever tools, methods, and materials make sense to you.

You can avoid a lot of frustration by selecting the best boards you can find. Look for pieces that are straight, flat, and free of twist. Sometimes that means going through every board they have; sometimes that means getting 2 boards so you can cut around flaws.