

### Dual IGBTMOD™ F-Series Module 600 Amperes/1200 Volts

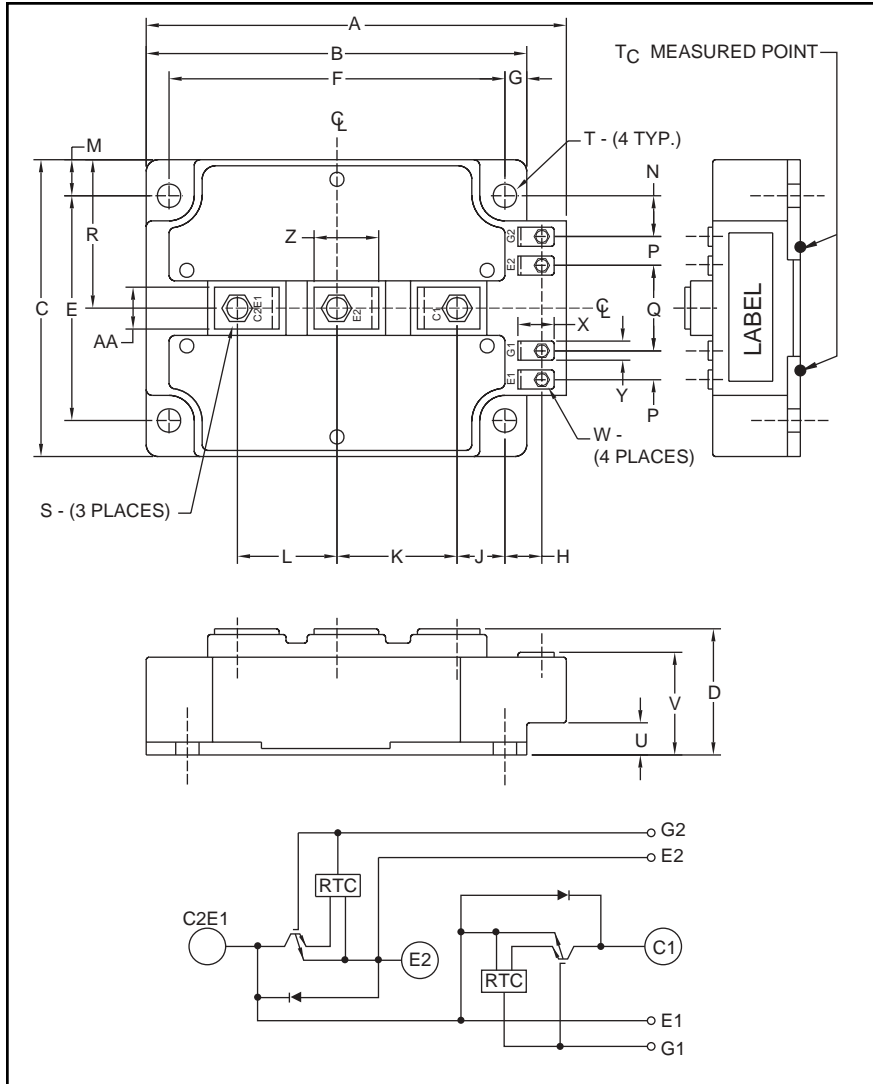

Outline Drawing and Circuit Diagram

Dimensions	Inches	Millimeters
A	5.51	140.0
B	5.12	130.0
C	5.12	130.0
D	1.38 +0/-0.02	35.0 +0/-0.5
E	4.33±0.01	110.0±0.25
F	4.33±0.01	110.0±0.25
G	0.39	10.0
H	0.45	11.5
J	0.54	13.8
K	1.72	43.8
L	1.42	36.0
M	0.39	10.0
N	0.80	20.4

Dimensions	Inches	Millimeters
P	0.57	14.5
Q	1.57	40.0
R	2.56	65.0
S	M8	M8
T	0.26 Dia.	6.5 Dia.
U	0.32	8.0
V	0.97 +0.04/-0.02	24.5 +1.0/-0.5
W	M4	M4
X	0.59	15.0
Y	0.35	9.0
Z	1.02	26.0
AA	0.79	20.0



#### Description:

Powerex IGBTMOD™ Modules are designed for use in switching applications. Each module consists of two IGBT Transistors in a half-bridge configuration with each transistor having a reverse-connected super-fast recovery free-wheel diode. All components and interconnects are isolated from the heat sinking baseplate, offering simplified system assembly and thermal management.

#### Features:

- Low Drive Power
- Low  $V_{CE(sat)}$
- Discrete Super-Fast Recovery Free-Wheel Diode
- Isolated Baseplate for Easy Heat Sinking

#### Applications:

- AC Motor Control
- Motion/Servo Control
- UPS
- Welding Power Supplies
- Laser Power Supplies

#### Ordering Information:

Example: Select the complete module number you desire from the table - i.e. CM600DU-24F is a 1200V ( $V_{CES}$ ), 600 Ampere Dual IGBTMOD™ Power Module.

Type	Current Rating Amperes	$V_{CES}$ Volts (x 50)
CM	600	24



Powerex, Inc., 200 E. Hillis Street, Youngwood, Pennsylvania 15697-1800 (724) 925-7272

**CM600DU-24F**  
**Dual IGBTMOD™ F-Series Module**  
 600 Amperes/1200 Volts

**Absolute Maximum Ratings,  $T_j = 25\text{ }^\circ\text{C}$  unless otherwise specified**

Ratings	Symbol	CM600DU-24F	Units
Junction Temperature	$T_j$	-40 to 150	$^\circ\text{C}$
Storage Temperature	$T_{stg}$	-40 to 125	$^\circ\text{C}$
Collector-Emitter Voltage (G-E SHORT)	$V_{CES}$	1200	Volts
Gate-Emitter Voltage (C-E SHORT)	$V_{GES}$	$\pm 20$	Volts
Collector Current ( $T_C = 25^\circ\text{C}$ )	$I_C$	600	Amperes
Peak Collector Current	$I_{CM}$	1200*	Amperes
Emitter Current** ( $T_C = 25^\circ\text{C}$ )	$I_E$	600	Amperes
Peak Emitter Current**	$I_{EM}$	1200*	Amperes
Maximum Collector Dissipation ( $T_C = 25^\circ\text{C}$ , $T_j \leq 150^\circ\text{C}$ )	$P_C$	1540	Watts
Mounting Torque, M8 Main Terminal	–	95	in-lb
Mounting Torque, M6 Mounting	–	40	in-lb
G(E) Terminal, M4	–	15	in-lb
Weight	–	1200	Grams
Isolation Voltage (Main Terminal to Baseplate, AC 1 min.)	$V_{iso}$	2500	Volts

**Static Electrical Characteristics,  $T_j = 25\text{ }^\circ\text{C}$  unless otherwise specified**

Characteristics	Symbol	Test Conditions	Min.	Typ.	Max.	Units
Collector-Cutoff Current	$I_{CES}$	$V_{CE} = V_{CES}$ , $V_{GE} = 0V$	–	–	2	mA
Gate Leakage Current	$I_{GES}$	$V_{GE} = V_{GES}$ , $V_{CE} = 0V$	–	–	80	$\mu\text{A}$
Gate-Emitter Threshold Voltage	$V_{GE(th)}$	$I_C = 60\text{mA}$ , $V_{CE} = 10V$	5.0	6	7.0	Volts
Collector-Emitter Saturation Voltage	$V_{CE(sat)}$	$I_C = 600\text{A}$ , $V_{GE} = 15V$ , $T_j = 25^\circ\text{C}$	–	1.95	2.55	Volts
		$I_C = 600\text{A}$ , $V_{GE} = 15V$ , $T_j = 125^\circ\text{C}$	–	2.05	–	Volts
Total Gate Charge	$Q_G$	$V_{CC} = 600V$ , $I_C = 600\text{A}$ , $V_{GE} = 15V$	–	6600	–	nC
Emitter-Collector Voltage**	$V_{EC}$	$I_E = 600\text{A}$ , $V_{GE} = 0V$	–	–	3.35	Volts

\* Pulse width and repetition rate should be such that the device junction temperature ( $T_j$ ) does not exceed  $T_{j(max)}$  rating.

\*\*Represents characteristics of the anti-parallel, emitter-to-collector free-wheel diode (FWDI).



Powerex, Inc., 200 E. Hillis Street, Youngwood, Pennsylvania 15697-1800 (724) 925-7272

**CM600DU-24F**  
**Dual IGBTMOD™ F-Series Module**  
 600 Amperes/1200 Volts

**Dynamic Electrical Characteristics,  $T_j = 25\text{ }^\circ\text{C}$  unless otherwise specified**

Characteristics	Symbol	Test Conditions	Min.	Typ.	Max.	Units
Input Capacitance	$C_{ies}$		–	–	230	nf
Output Capacitance	$C_{oes}$	$V_{CE} = 10V, V_{GE} = 0V$	–	–	10	nf
Reverse Transfer Capacitance	$C_{res}$		–	–	6	nf
Resistive	Turn-on Delay Time	$V_{CC} = 600V, I_C = 600A,$ $V_{GE1} = V_{GE2} = 15V,$ $R_G = 1.0\Omega,$ Inductive Load	–	–	450	ns
Load	Rise Time		$t_r$	–	–	200
Switch	Turn-off Delay Time	Switching Operation	–	–	800	ns
Times	Fall Time		$t_f$	–	–	300
Diode Reverse Recovery Time*	$t_{rr}$		–	–	500	ns
Diode Reverse Recovery Charge*	$Q_{rr}$	$I_E = 600A$	–	43.2	–	$\mu C$

**Thermal and Mechanical Characteristics,  $T_j = 25\text{ }^\circ\text{C}$  unless otherwise specified**

Characteristics	Symbol	Test Conditions	Min.	Typ.	Max.	Units
Thermal Resistance, Junction to Case	$R_{th(j-c)Q}$	Per IGBT 1/2 Module, $T_c$ Reference Point per Outline Drawing	–	–	0.081	$^\circ C/W$
Thermal Resistance, Junction to Case	$R_{th(j-c)R}$	Per FWDi 1/2 Module, $T_c$ Reference Point per Outline Drawing	–	–	0.11	$^\circ C/W$
Thermal Resistance	$R_{th(j-c)Q}$	Per IGBT 1/2 Module $T_c$ Reference Point Under Chips	–	–	0.032**	$^\circ C/W$
Contact Thermal Resistance	$R_{th(c-f)}$	Per Module, Thermal Grease Applied	–	0.010	–	$^\circ C/W$
External Gate Resistance	$R_G$		1.0	–	52	$\Omega$

\*Represents characteristics of the anti-parallel, emitter-to-collector free-wheel diode (FWDi).

\*\*If you use this value,  $R_{th(f-a)}$  should be measured just under the chips.



Powerex, Inc., 200 E. Hillis Street, Youngwood, Pennsylvania 15697-1800 (724) 925-7272

**CM600DU-24F**  
**Dual IGBTMOD™ F-Series Module**  
 600 Amperes/1200 Volts

