

DETAILS

Product Number	CN13518_MIRELLA-50-M-CL
Family	Mirella
Type	RefPack
Color	metal
Diameter	49,9 mm
Height	24 mm
Style	round
Optic Material	PC
Holder Material	
Fastening	glue
Status	production ready
ROHS Compliant	Yes
Date Updated	1/11/2016



OPTICAL PROPERTIES

LED	Viewing	Light	Efficiency	cd/lm	Connector
	Angle	Beam			
BXRA LS	27 deg	Medium	84 %	2.400	-
CLL01x	35 deg	Medium	83 %	1.700	-
CLL02x/CLU02x (LES10)	30 deg	Medium	84 %	2.200	-
CLU720/721	35 deg	Medium	85 %	1.700	-
CLU710/711	30 deg	Medium	85 %	2.100	-
CLU700/701	24 deg	Medium	83 %	2.900	-
MT-G2	35 deg	Medium	85 %	1.800	-
CXA/B 15xx	30 deg	Medium	83 %	2.400	-
CXA/B 13xx	23 deg	Medium	81 %	2.900	-
CXA/B 1816 & CXA/B 1820 & CXA 1850	37 deg	Medium	82 %	1.800	-
XHP50	31 deg	Medium	86 %	2.000	-
XHP70	35 deg	Medium	86 %	1.800	-
MHD-E/G	35 deg	Medium	88 %	1.700	-
COB 4W	27 deg	Medium	84 %	2.600	-
LUXEON S1000	22 deg	Medium	83 %	3.400	-
LUXEON CoB 1202/1203	33 deg	Medium	85 %	2.000	-
CXM-9	33 deg	Medium	85 %	1.900	-
COB L-Type (LES 9)	33 deg	Medium	86 %	2.100	-
NSCxL036A	30 deg	Medium	85 %	2.300	-
Soleriq S13	38 deg	Medium	82 %	1.600	-
Duris S10	29 deg	Medium	83 %	2.500	-
Soleriq S9	sim: 34	Medium	sim: 87 %	sim: 2.000	-
ZC4/6	30 deg	Medium	82 %	2.300	-
STARK SLE PURE G3 LES10	30 deg	Medium	81 %	2.200	-

Relative intensity of CN13518_MIRELLA-50-M-CL-(LS)

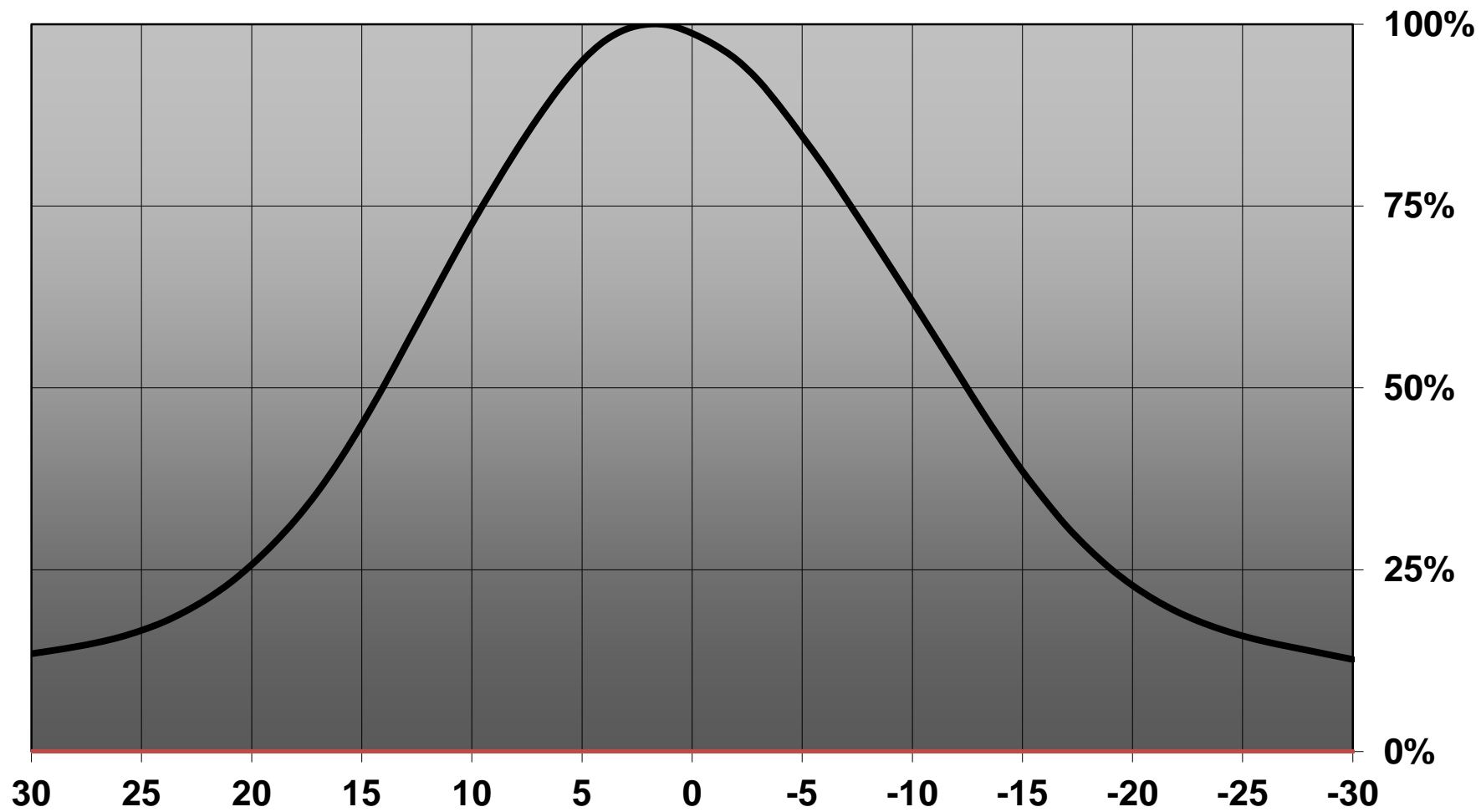

Relative intensity of CN13518_MIRELLA-50-M-CL-(CLL010)

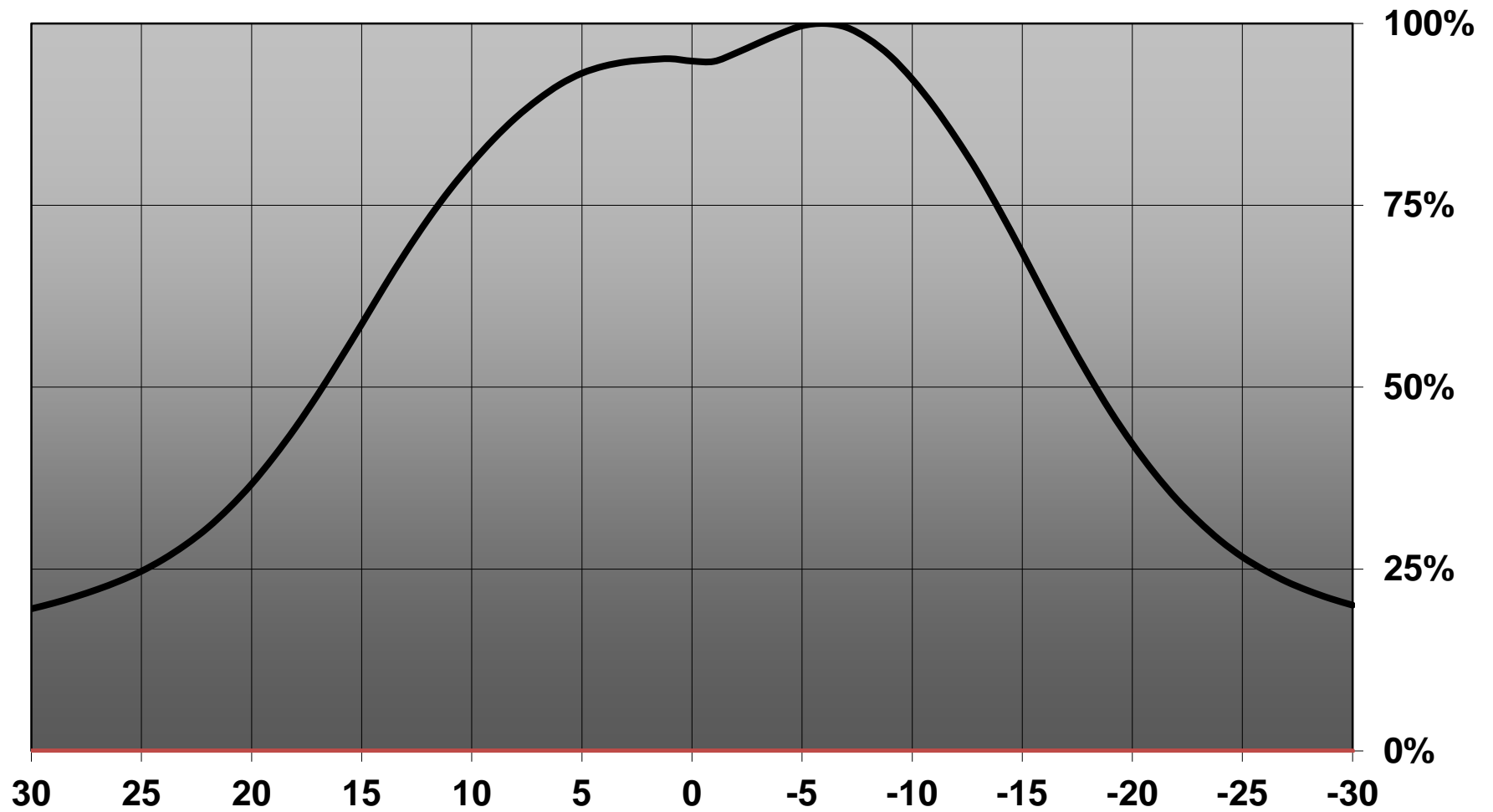

Relative intensity of CN13518_MIRELLA-50-M-CL-(CLL020)

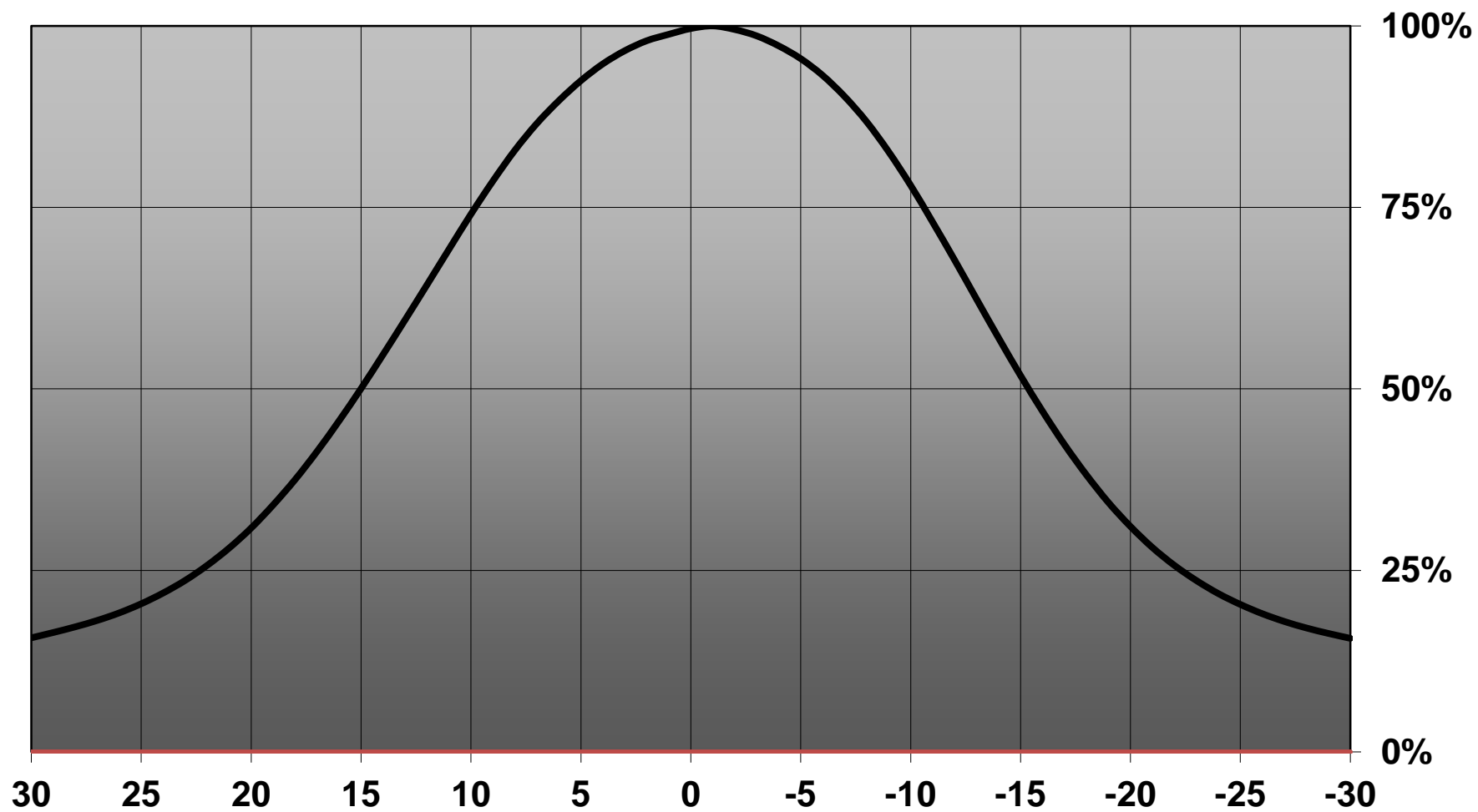

Relative intensity of CN13518_MIRELLA-50-M-CL-(MTG2)

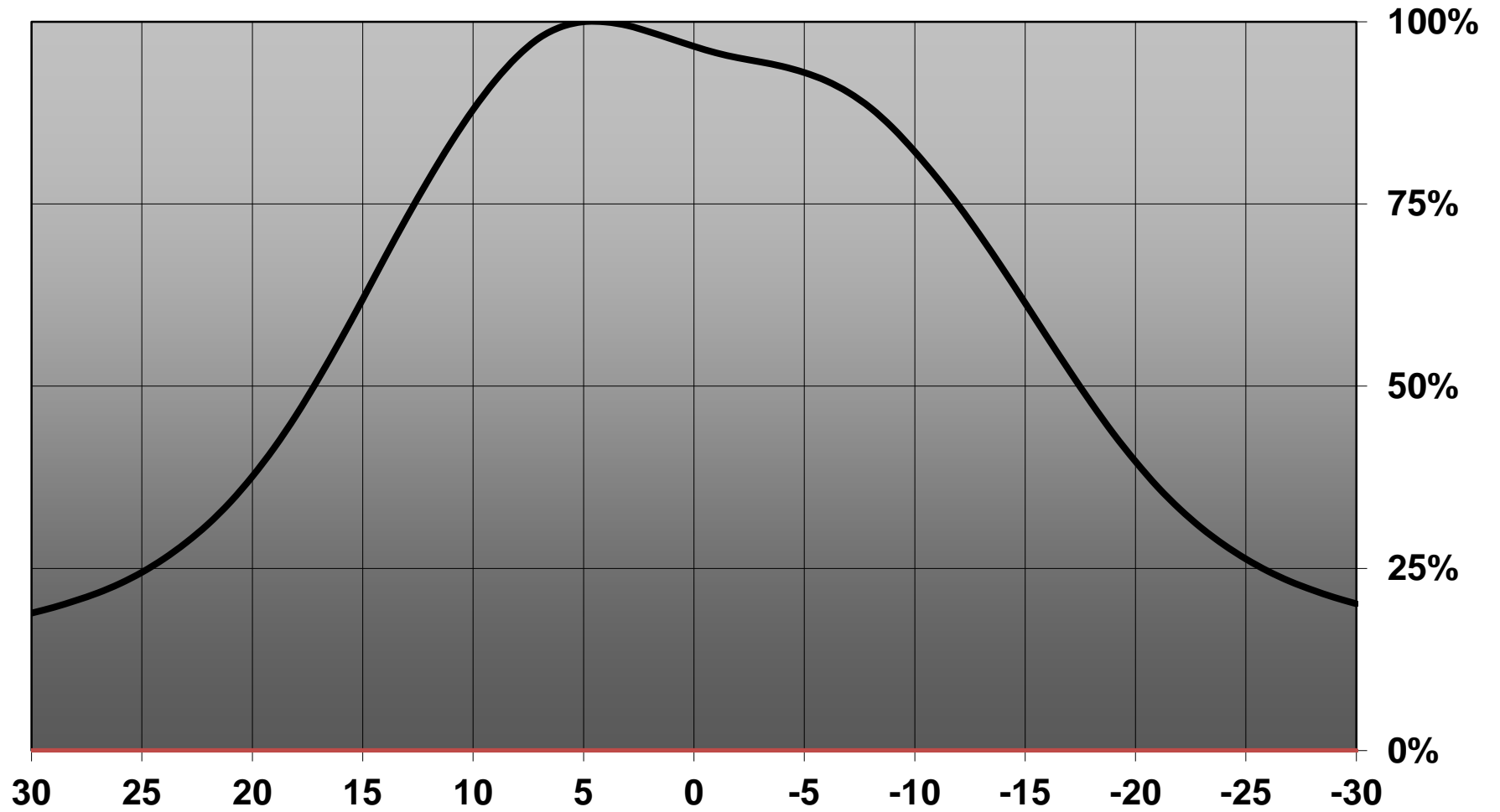

Relative intensity of CN13518_MIRELLA-50-M-CL-(CXA15)

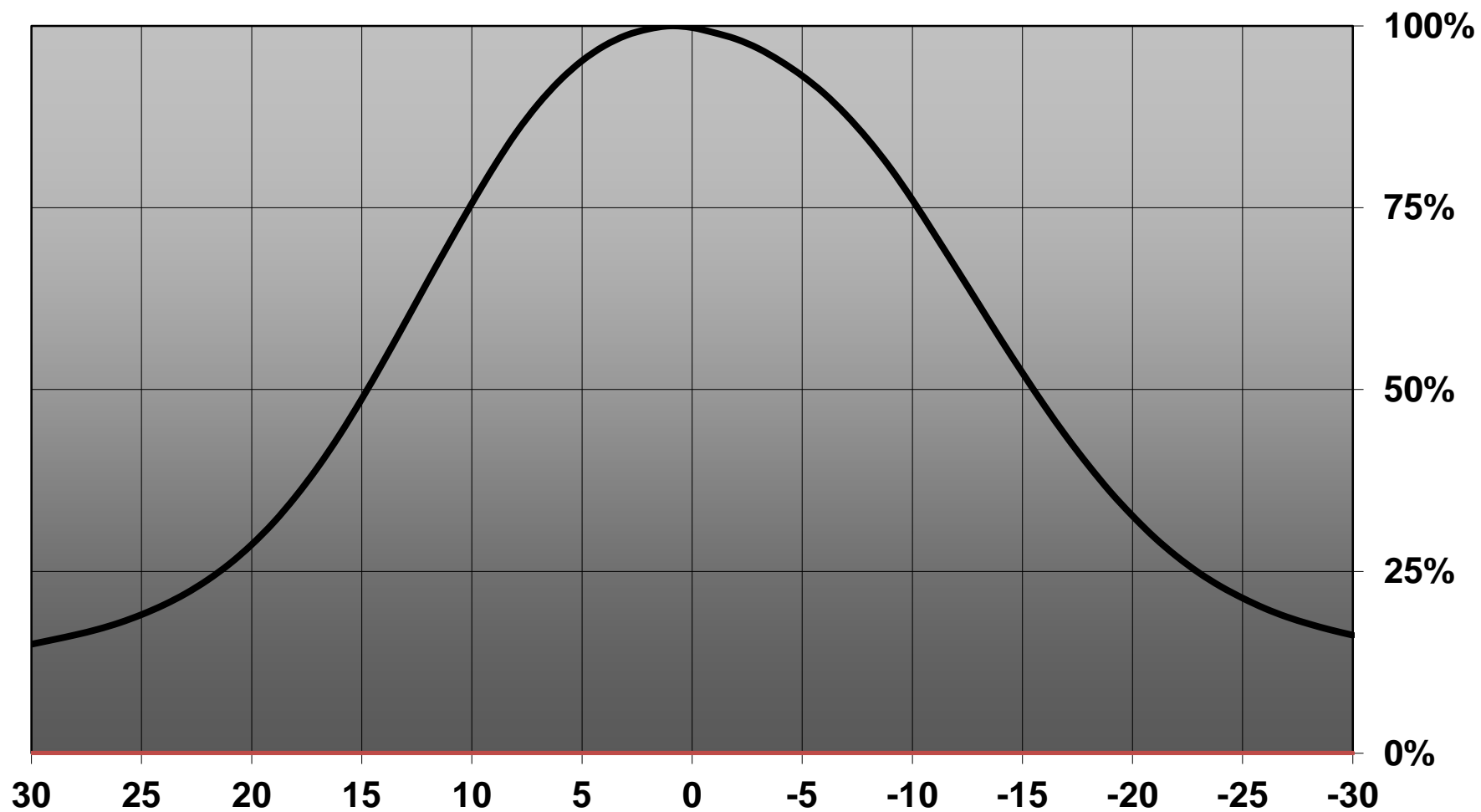

Relative intensity of CN13518_MIRELLA-50-M-CL_(CXA1304)

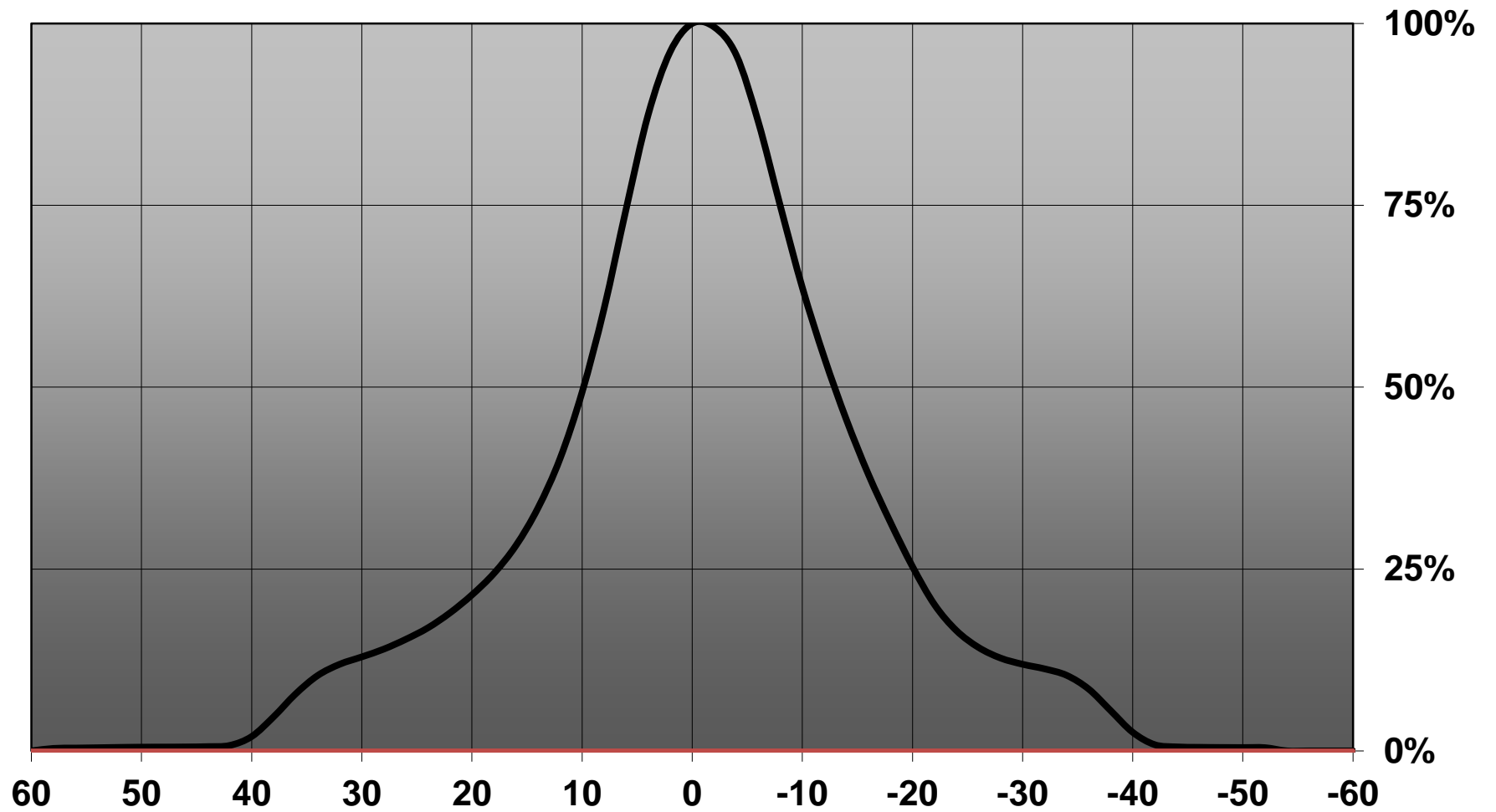

Relative intensity of CN13518_MIRELLA-50-M-CL_(CXA1816)

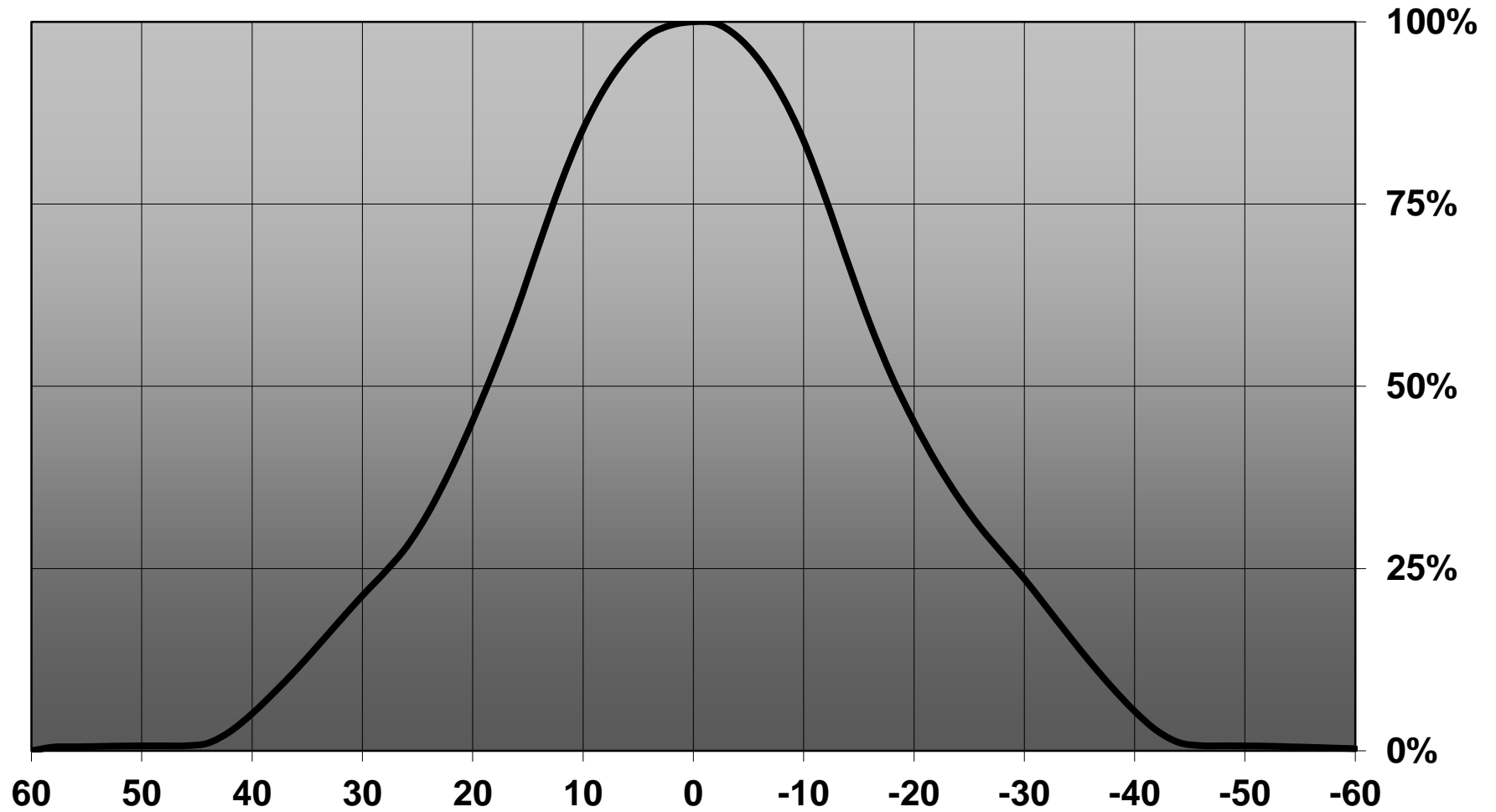

Relative intensity of CN13518_MIRELLA-50-M-CL-(COB4W)

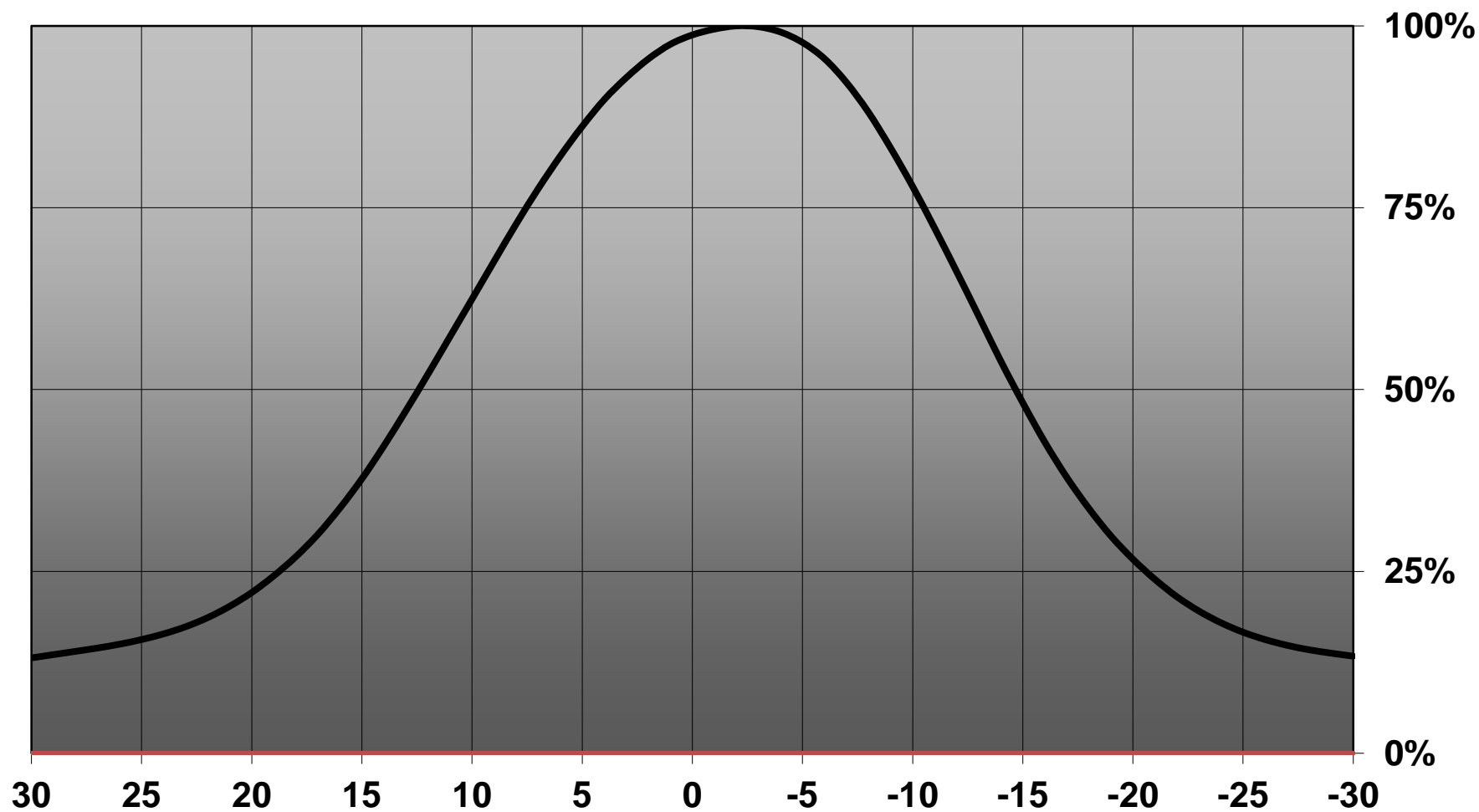

Relative intensity of CN13518_MIRELLA-50-M-CL-(LuxS)

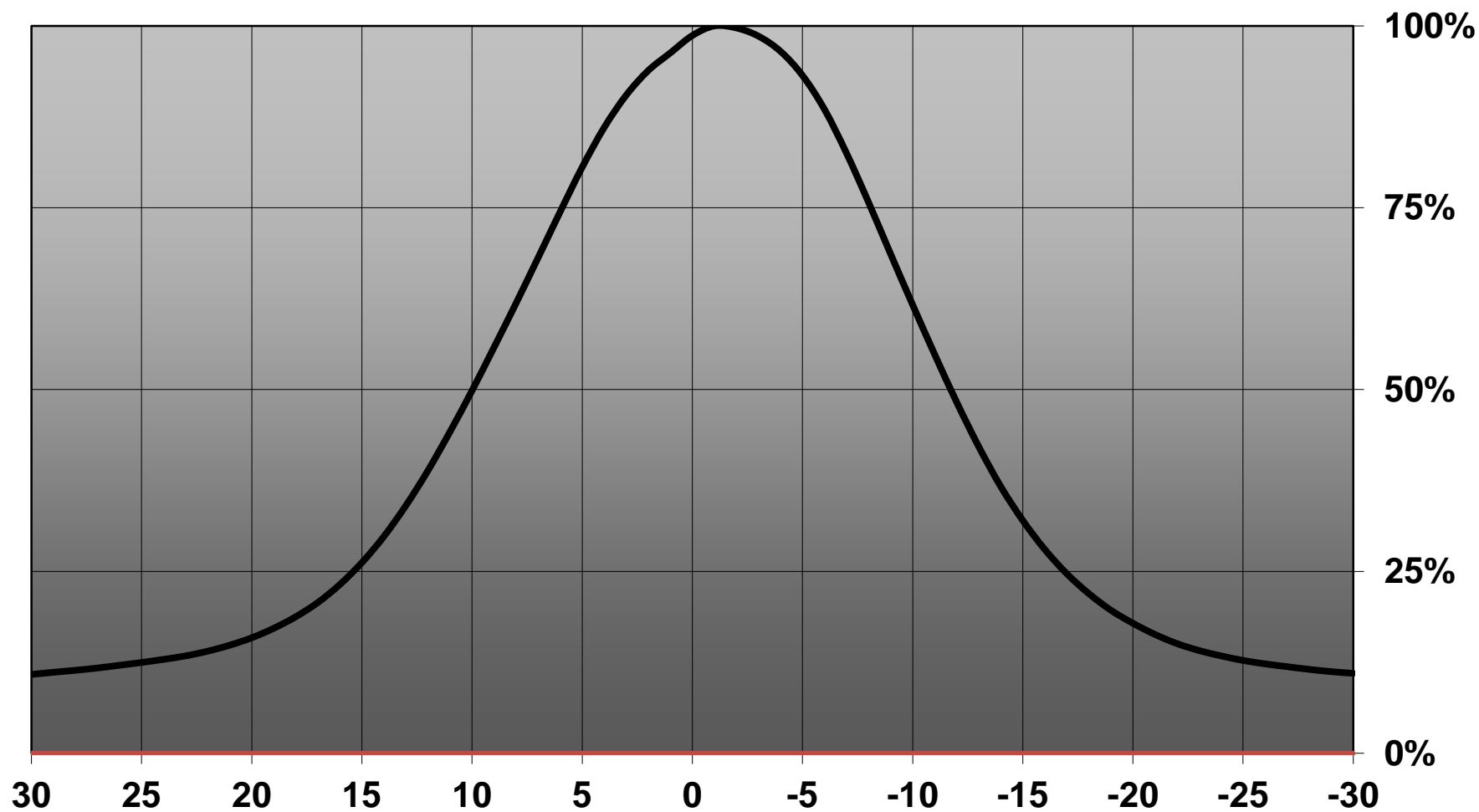

Relative intensity of CN13518_MIRELLA-50-M-CL_(Duris_S10)

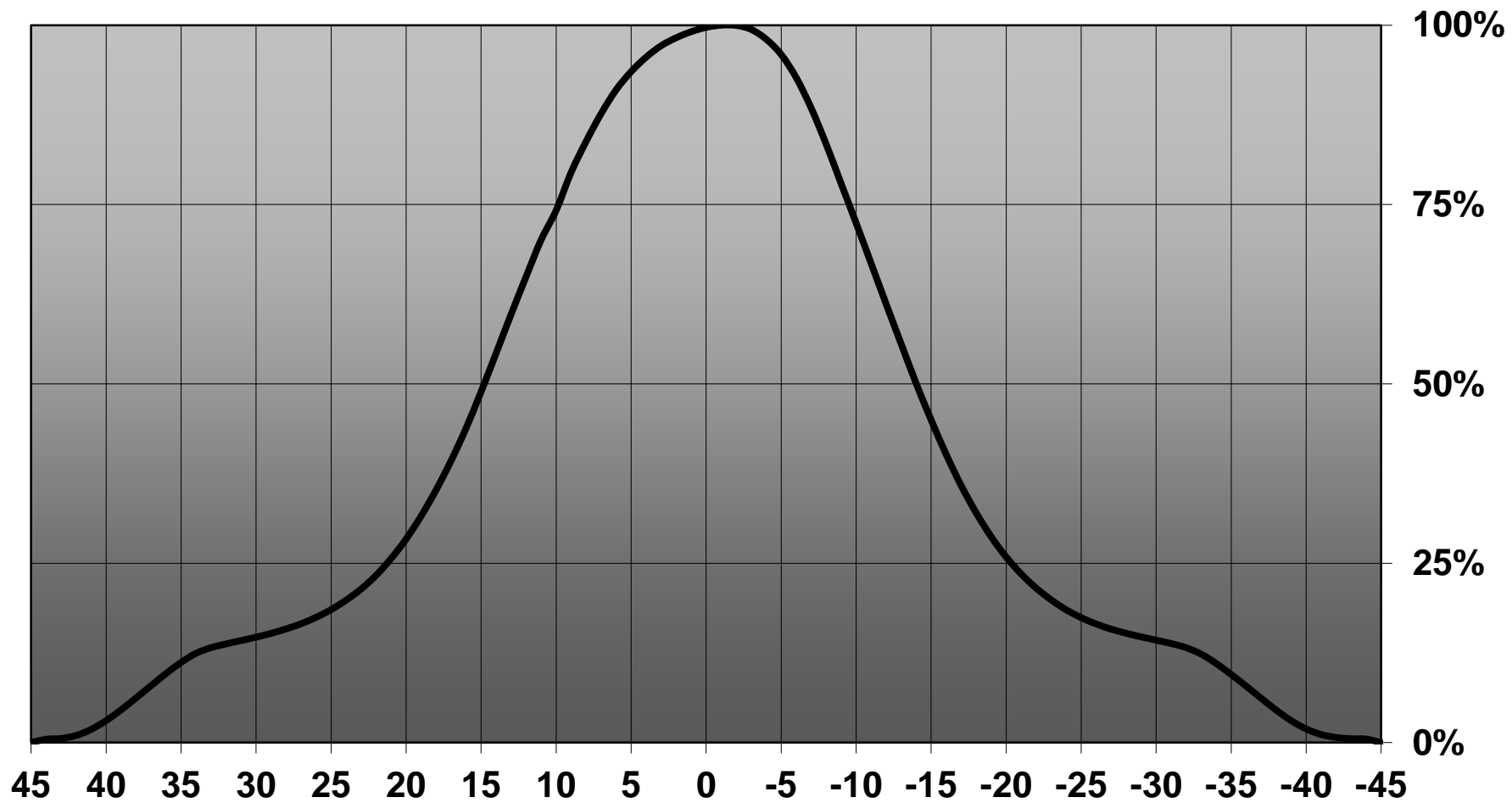

H G F E D C B A

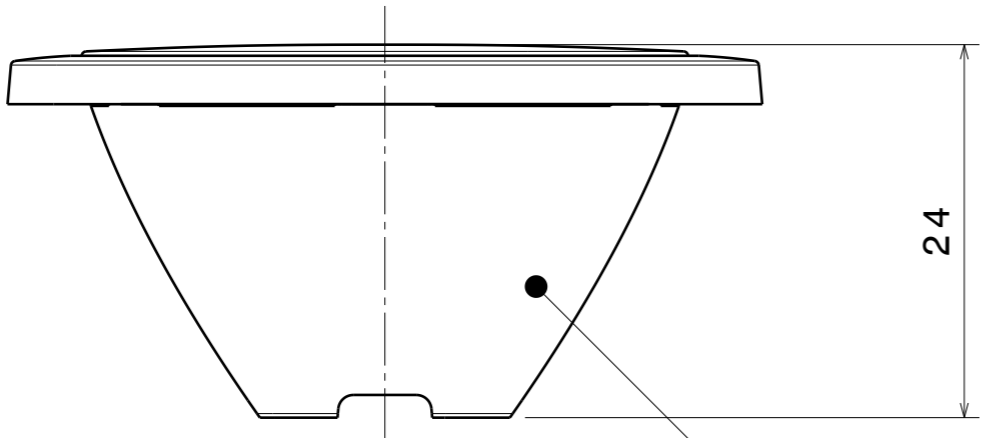

Front view

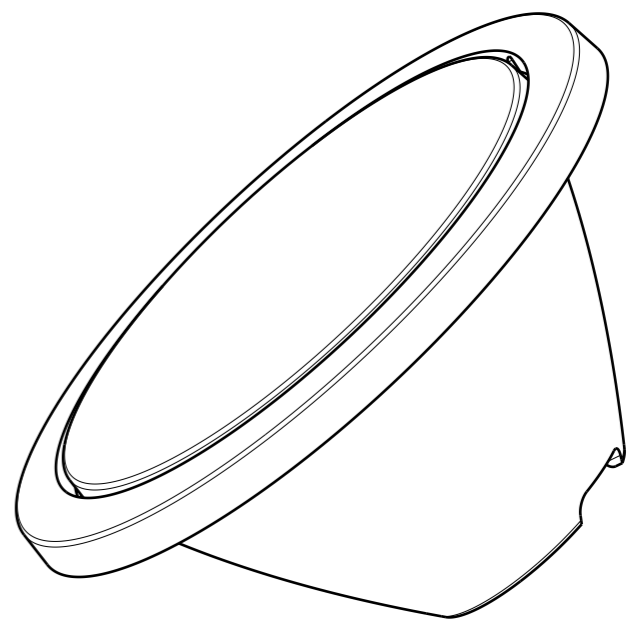

Isometric view

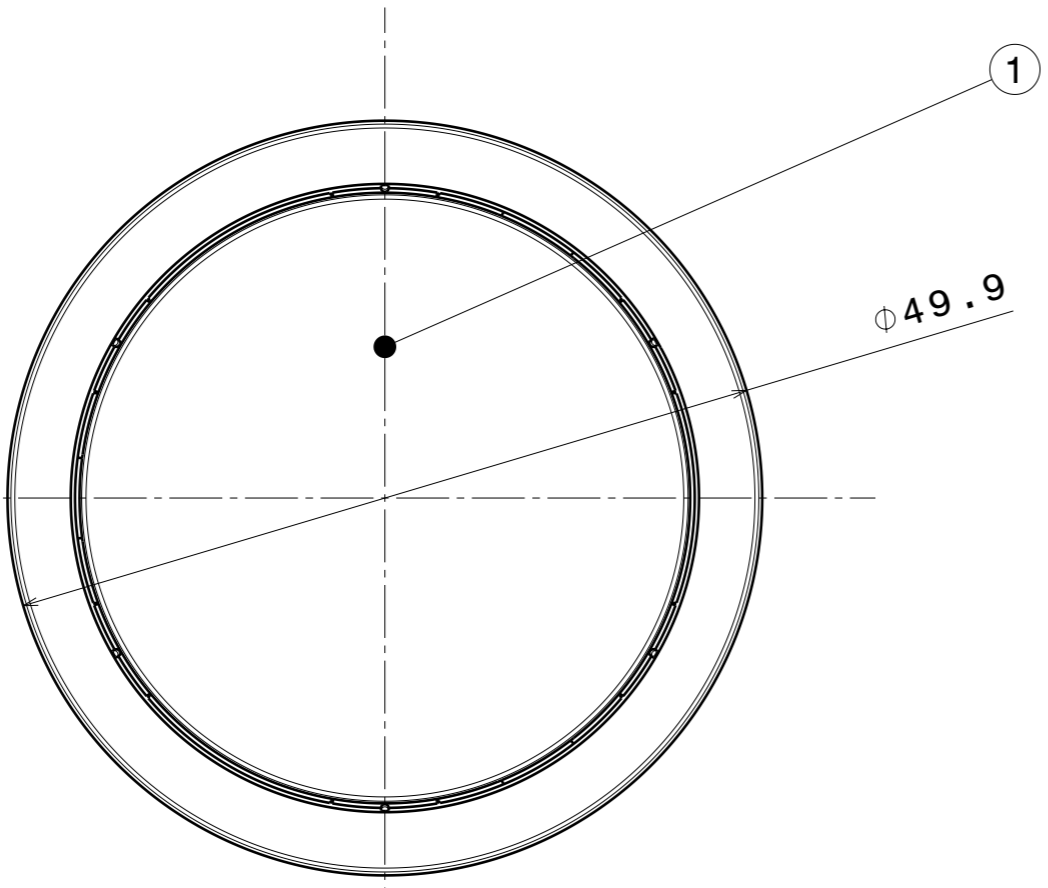

Front view

INDEX	PART NO	DESCRIPTION	MATERIAL
1	C13333	MIRELLA-CL	PC
2	C12477	MIRELLA-50-M	PC

Tolerances if not otherwise shown
 According to DIN ISO 2768-1
 Linear measures:
 Up to 30mm class M, otherwise class C.
 According to DIN ISO 2768-2
 Form and position: class L

LEDiL Ledil Oy
 Salorankatu 10
 FIN 24240 SALO
 Finland

THIRD ANGLE PROJECTION:

DRAWING TITLE
CN13518_MIRELLA-50-M-CL

This drawing is the property
 of LEDiL Oy. It may not be
 reproduced, copied or
 communicated without a written
 agreement with LEDiL Oy."

SIZE	PART NUMBER
A3	CN13518

SCALE	2:1	WEIGHT	(g)	SHEET	1/1
-------	-----	--------	-----	-------	-----

H G B A

Ledil CN13518_MIRELLA-50-M-CL_(CLU720) / LDC (Linear)

Luminaire: Ledil CN13518_MIRELLA-50-M-CL_(CLU720)
Lamps: 1 x CITIZEN_CLU720_(CLU720-1206B8-273M2)
_1298.17lm@250mA_CCT=2700K_P=8.3W_I=0.25A

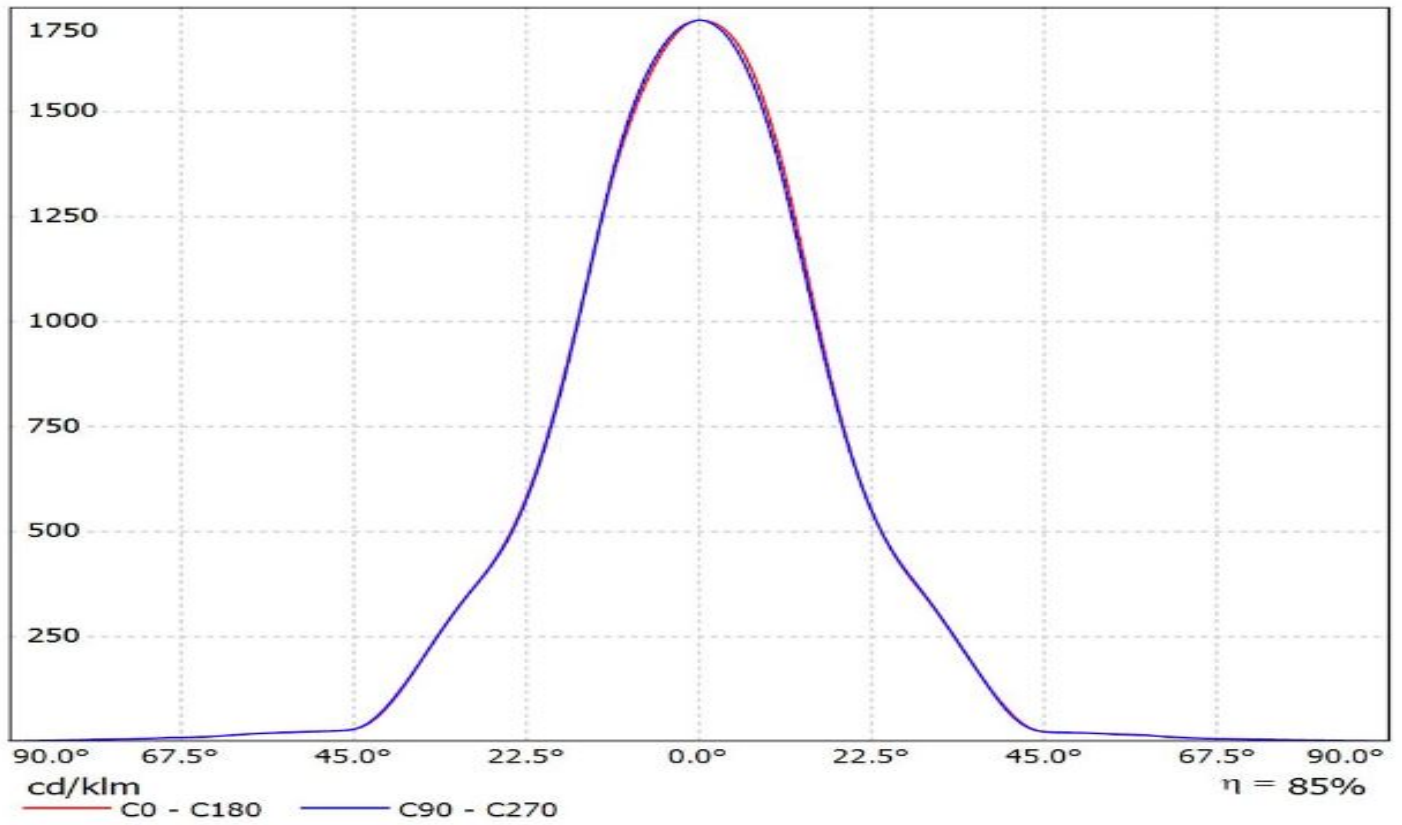

Luminaire: Ledil CN13518_MIRELLA-50-M-CL_(CLU710)

Lamps: 1 x CITIZEN_CLU710_(CLU710-1204B8-273M2G1)_1212.66lm@250mA_P=8.5W_I=0.25A

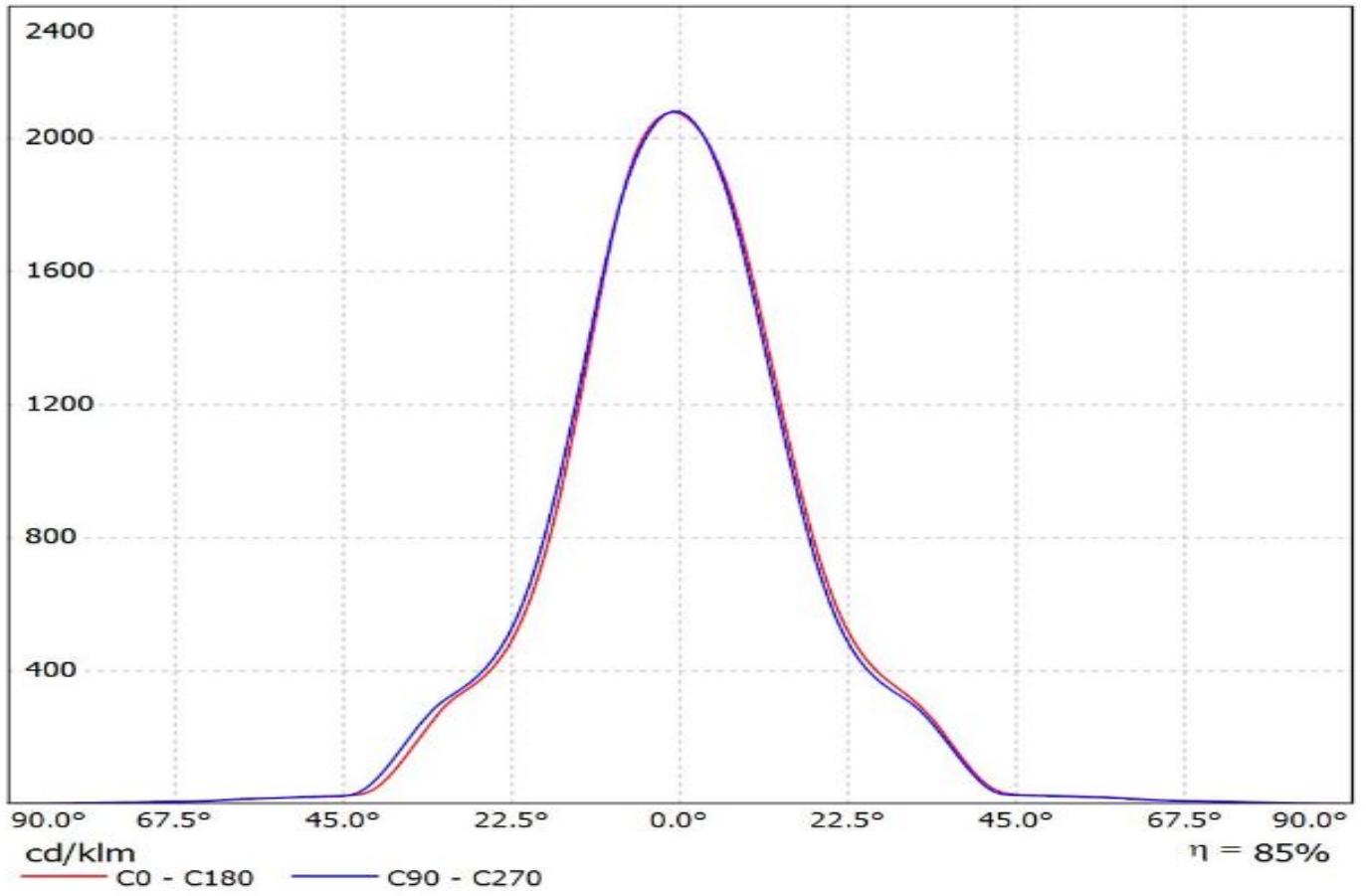

Luminaire: Ledil CN13518_MIRELLA-50-M-CL_(CLU700)
Lamps: 1 x Citizen_CLU700_395.592lm@100mA_P=2.815W_I=0.1A

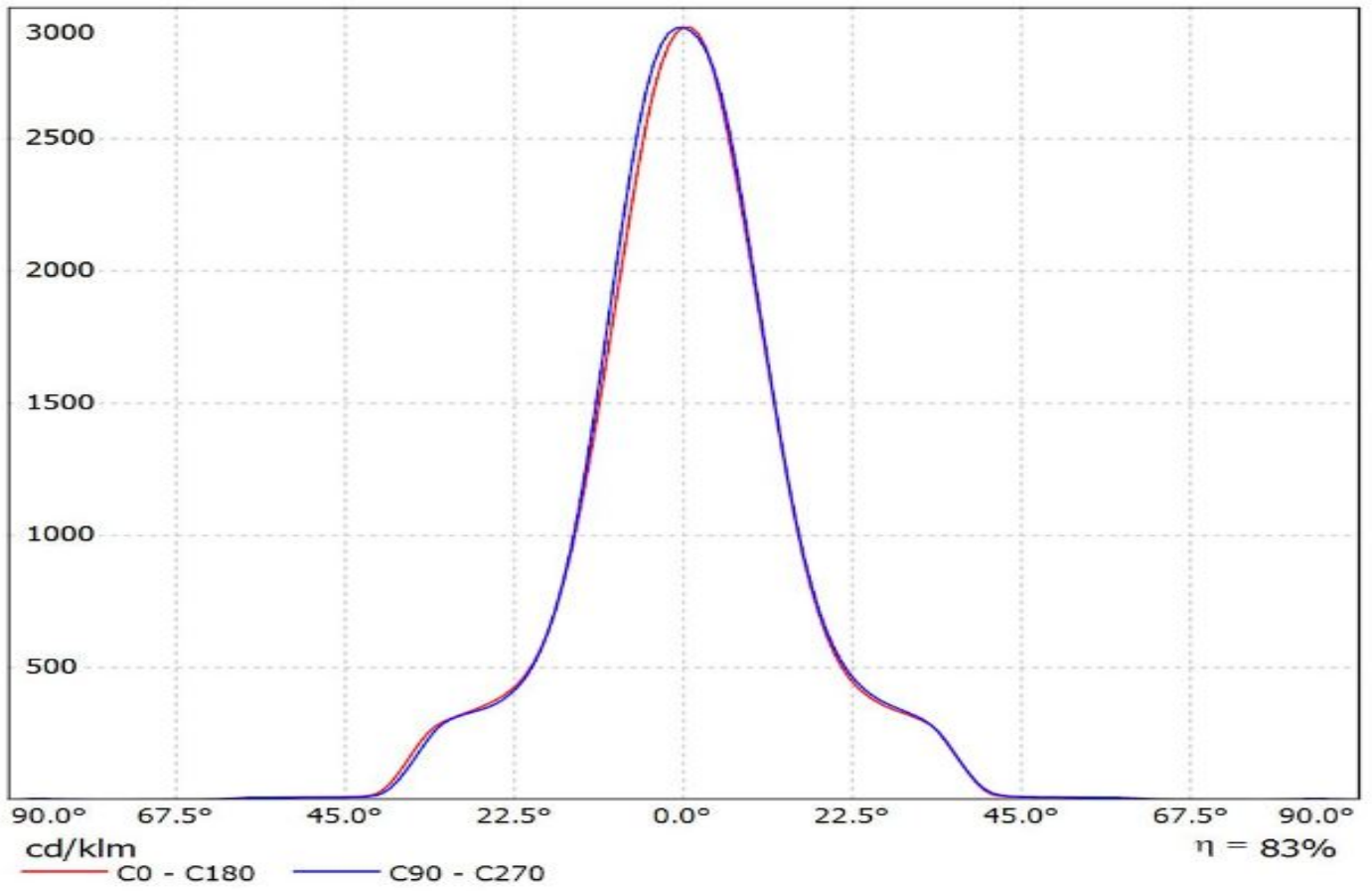

Luminaire: LEDiL Oy CN13518_MIRELLA-50-M-CL_(CREE_XHP50_WARM_WHITE)
Lamps: 1 x CREE_XHP50_WARM_WHITE_194.925lm@250mA_P=1.39897W_I=0.2499A

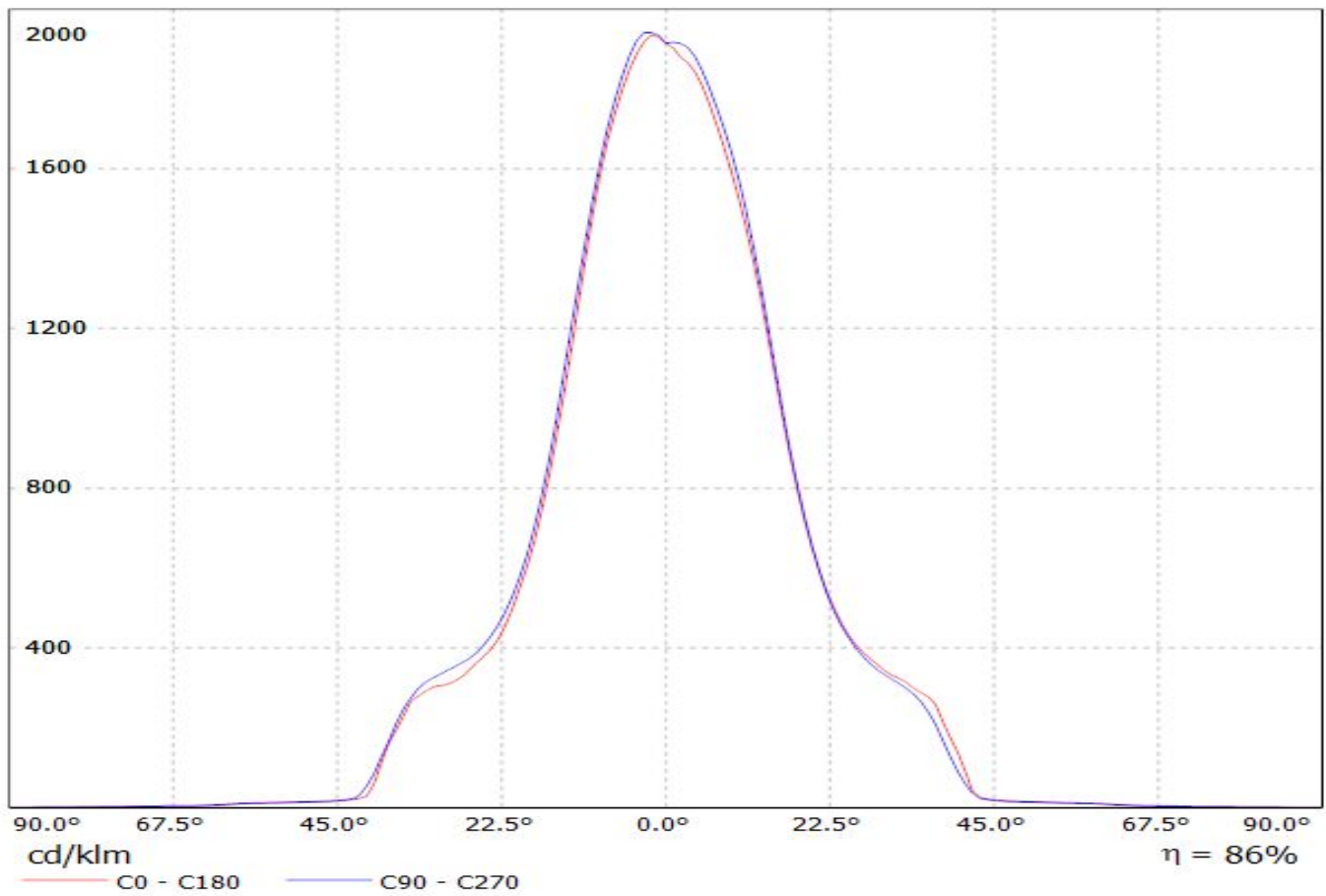

Luminaire: LEDiL Oy CN13518_MIRELLA-50-M-CL_(Cree_XHP70)
Lamps: 1 x Cree_XHP70_258.083lm@250mA_P=1.38117W_I=0.2499A

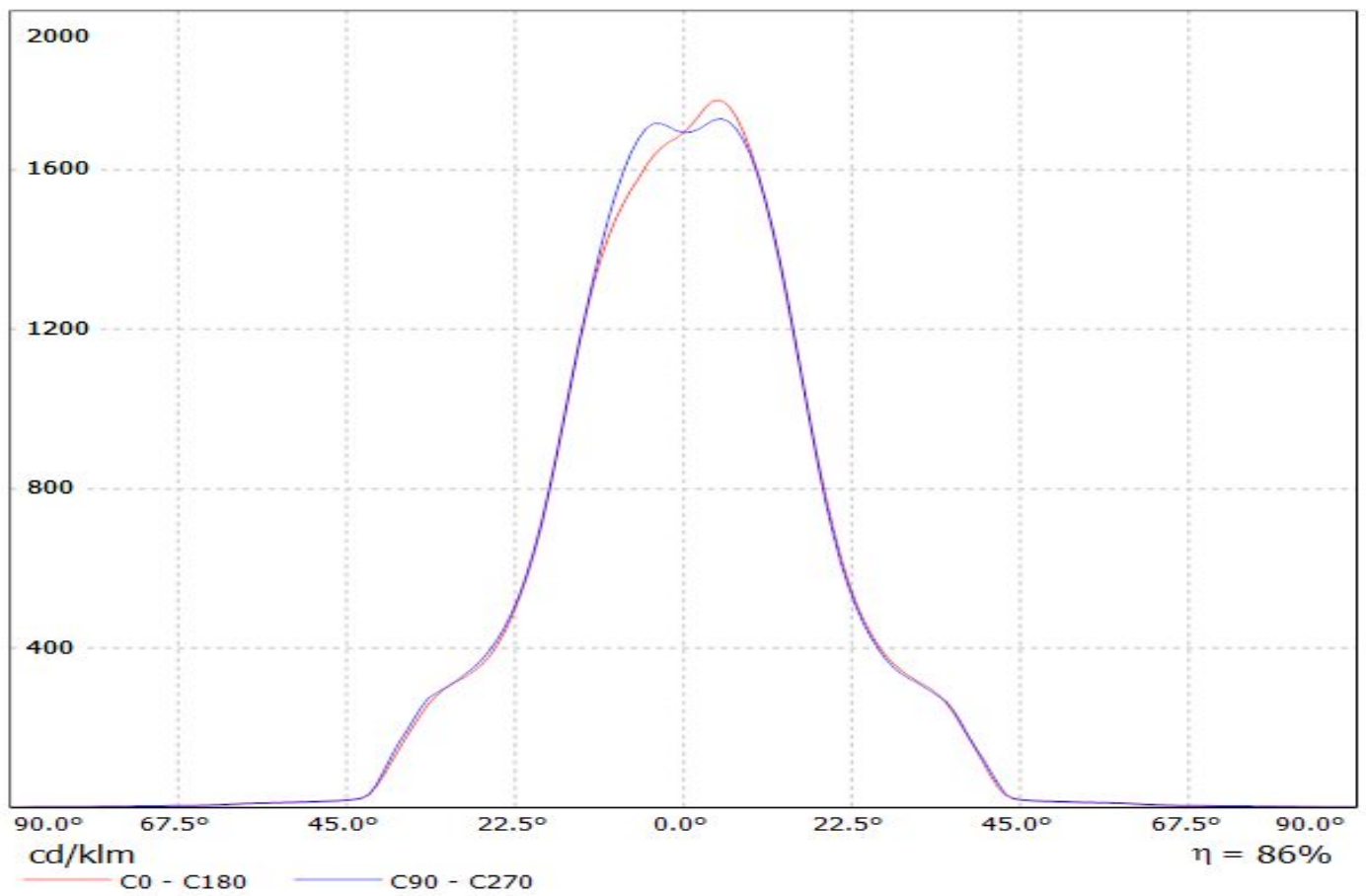

Luminaire: Ledil CN13518_MIRELLA-50-M-CL_(MHD-G)
Lamps: 1 x Cree MHD-G_528.649lm@100mA_P=3.0W_I=0.100A

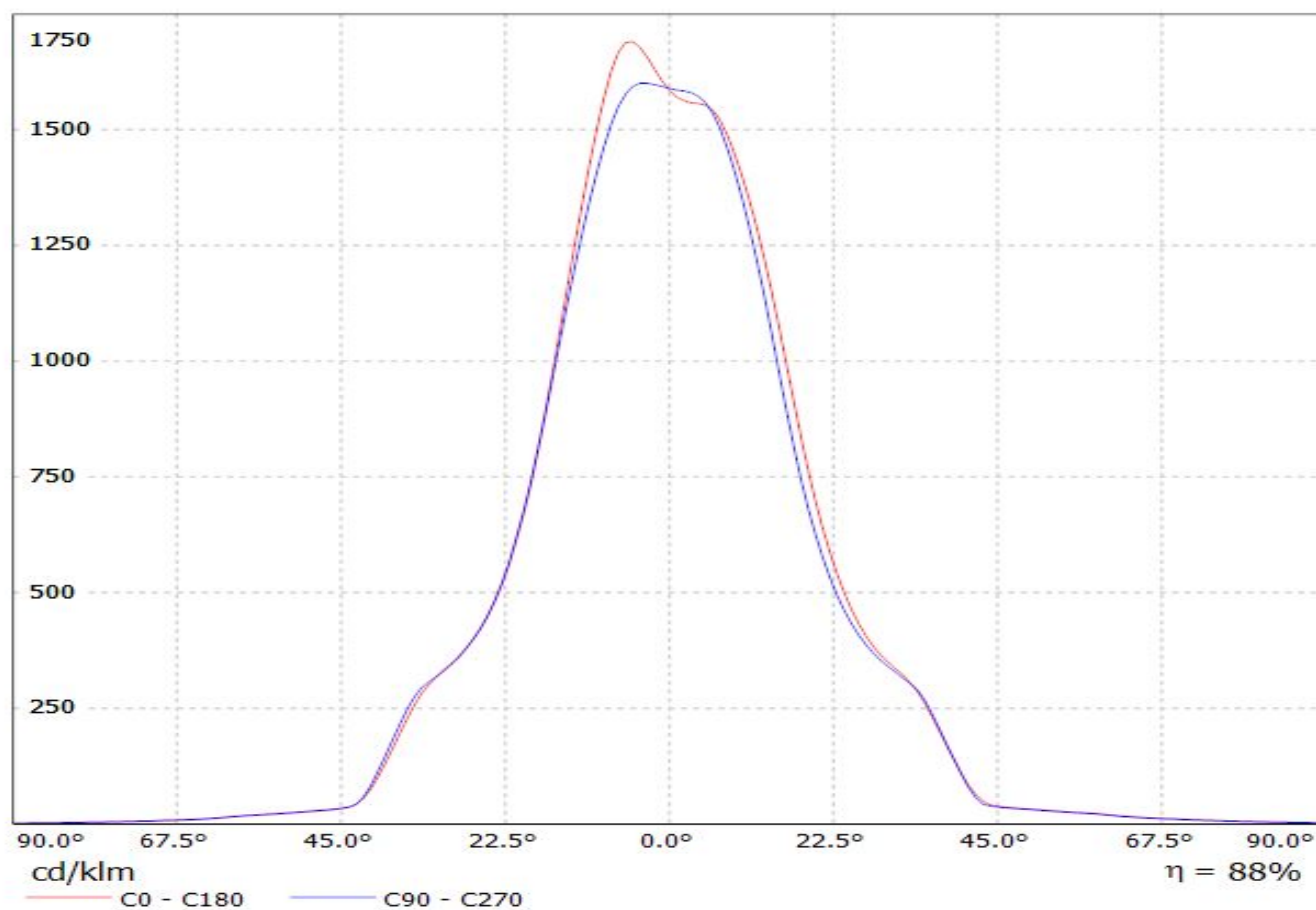

Luminaire: Ledil Oy CN13518_MIRELLA-50-M-CL_(Luxeon_CoB_1203) Efficiency=85%
Lamps: 1 x Luxeon Cob 1203 (LHC1-3080-1203) 824lm @ 250mA CCT=3000K P=8.7W I=250mA

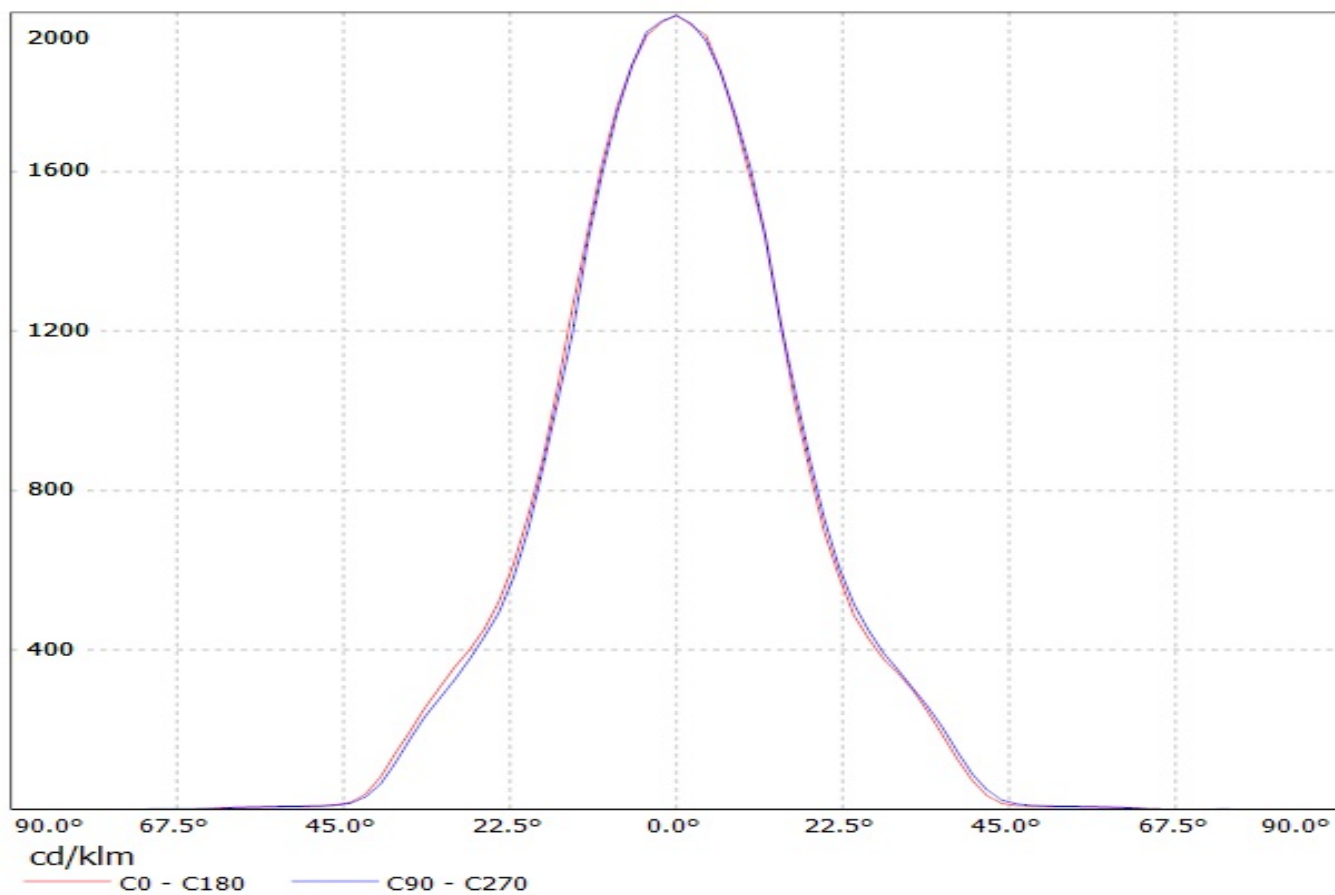

Luminaire: LEDiL Oy CN13518_MIRELLA-50-M-CL_(CXM-9)

Lamps: 1 x Luminus_XNOVA_CXM-9_(AA00)_974.297lm@240mA_P=8.2836W_I=240mA

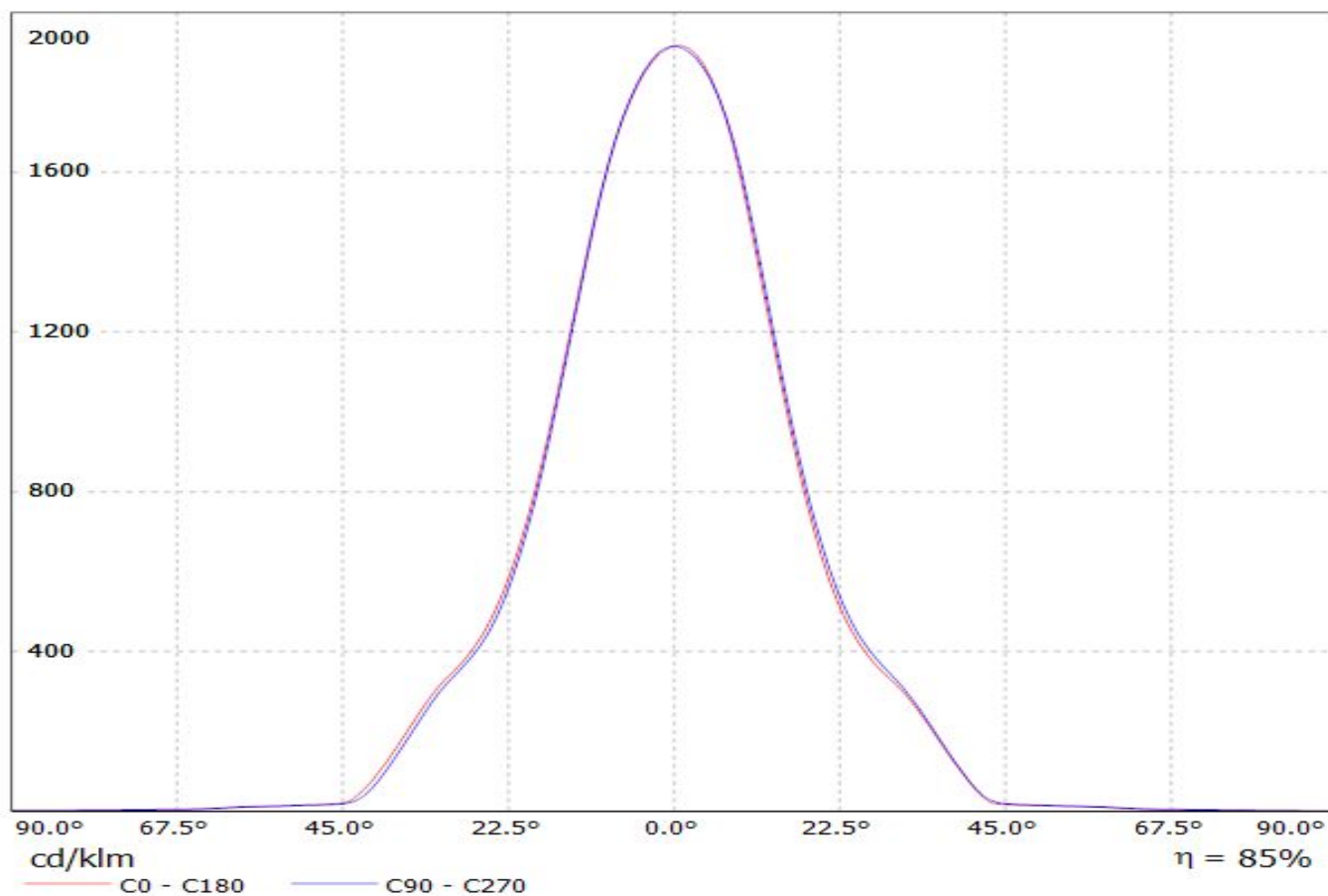

Luminaire: Ledil Oy CN13518_MIRELLA-50-M-CL (NSBxL066A 930lm @ 250mA) Efficiency=86%
Lamps: 1 x NSBxL066A 930lm @ 250mA (NSBLL066AE) CCT=3536K P=7,75W I=250mA

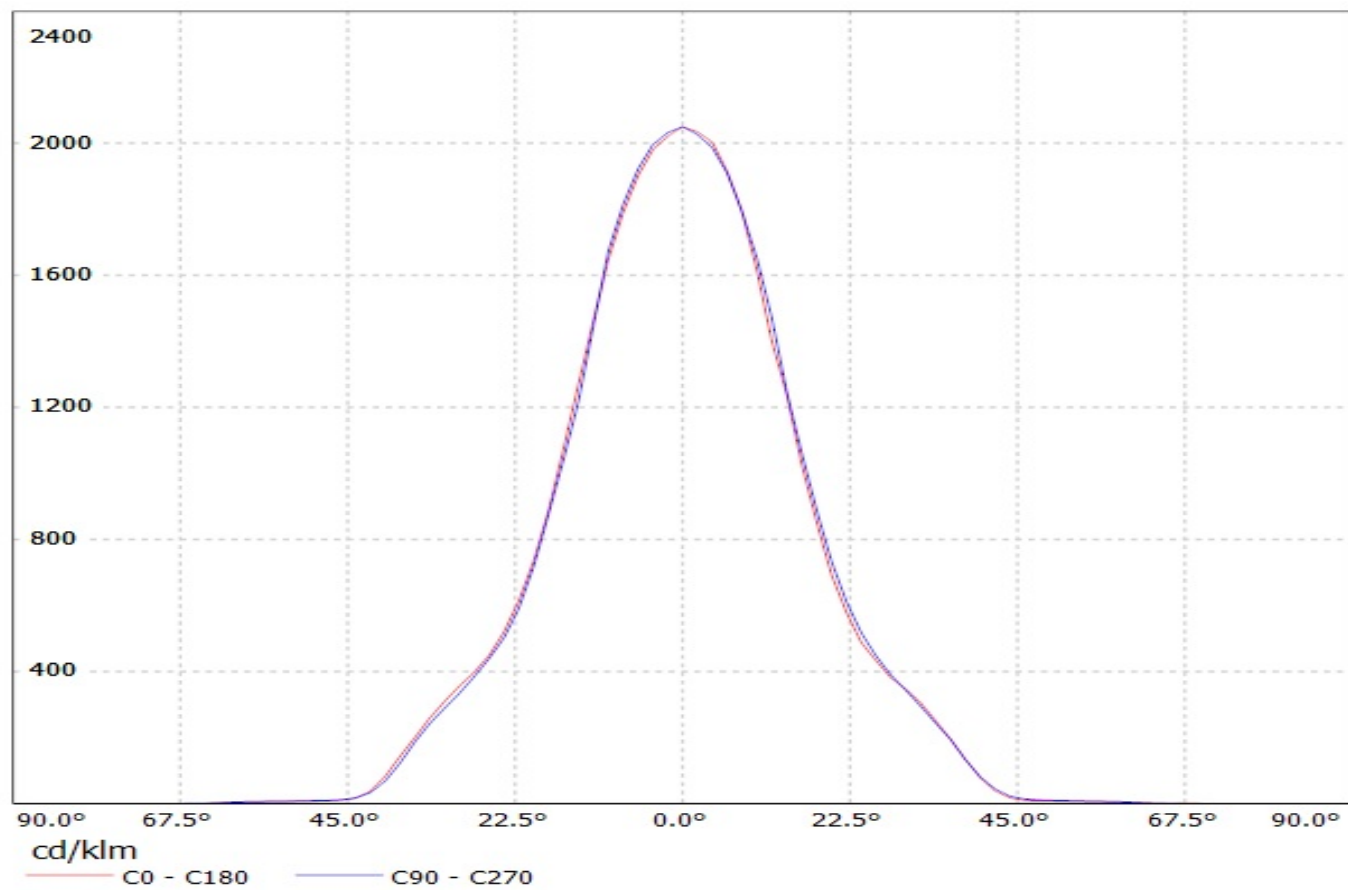

Luminaire: Ledil Oy CN13518_MIRELLA-50-M-CL (Nichia NSCxL036A 434lm @ 100mA) Efficiency=85%
Lamps: 1 x Nichia NSCxL036A 434lm @ 100mA (NSCLL036A) CCT=3000K P=3,4W I=100mA

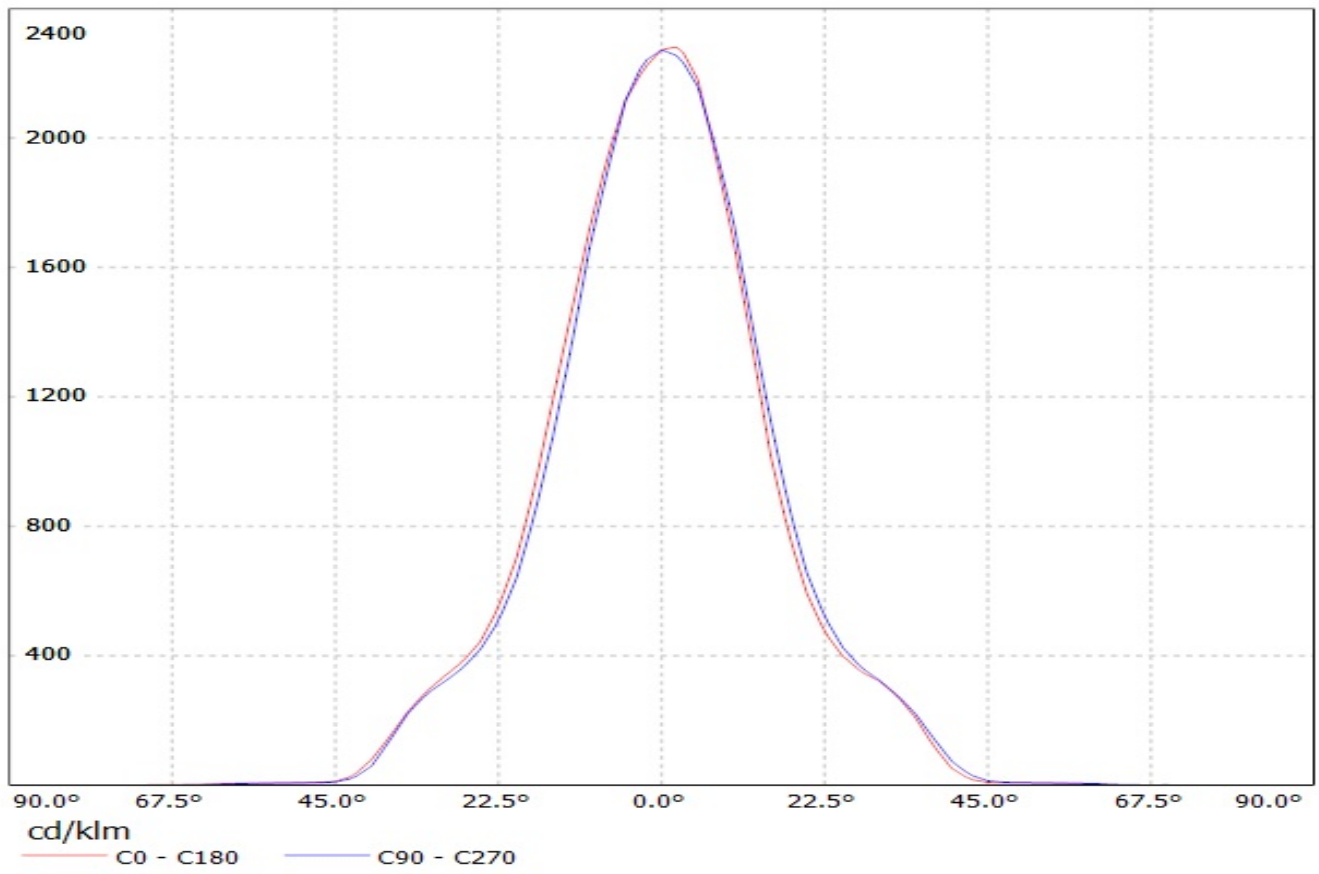

Luminaire: LEDil Oy CN13518_MIRELLA-50-M-CL_(Soleriq_S13) Efficiency=82%
Lamps: 1 x Osram Soleriq S13 (GW KAGHB1.EM) 832lm @ 250mA CCT=3100K P=7.4W I=250mA

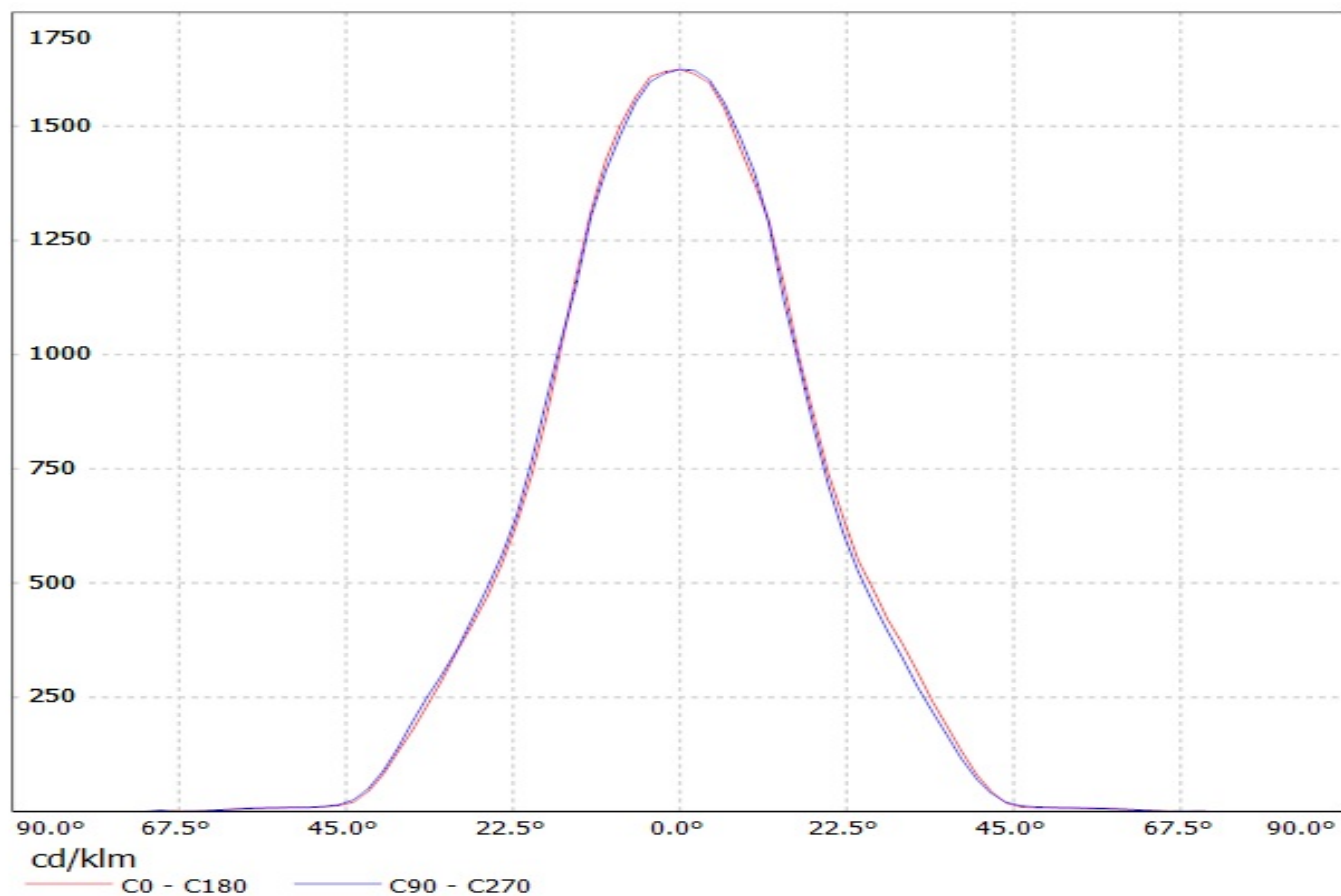

Luminaire: Ledil Oy CN13518_MIRELLA-50-M-CL_(Soleriq_S9)_SIMULATED
Lamps: 1 x Osram Soleriq S9 (GW KAFJB3.EM)

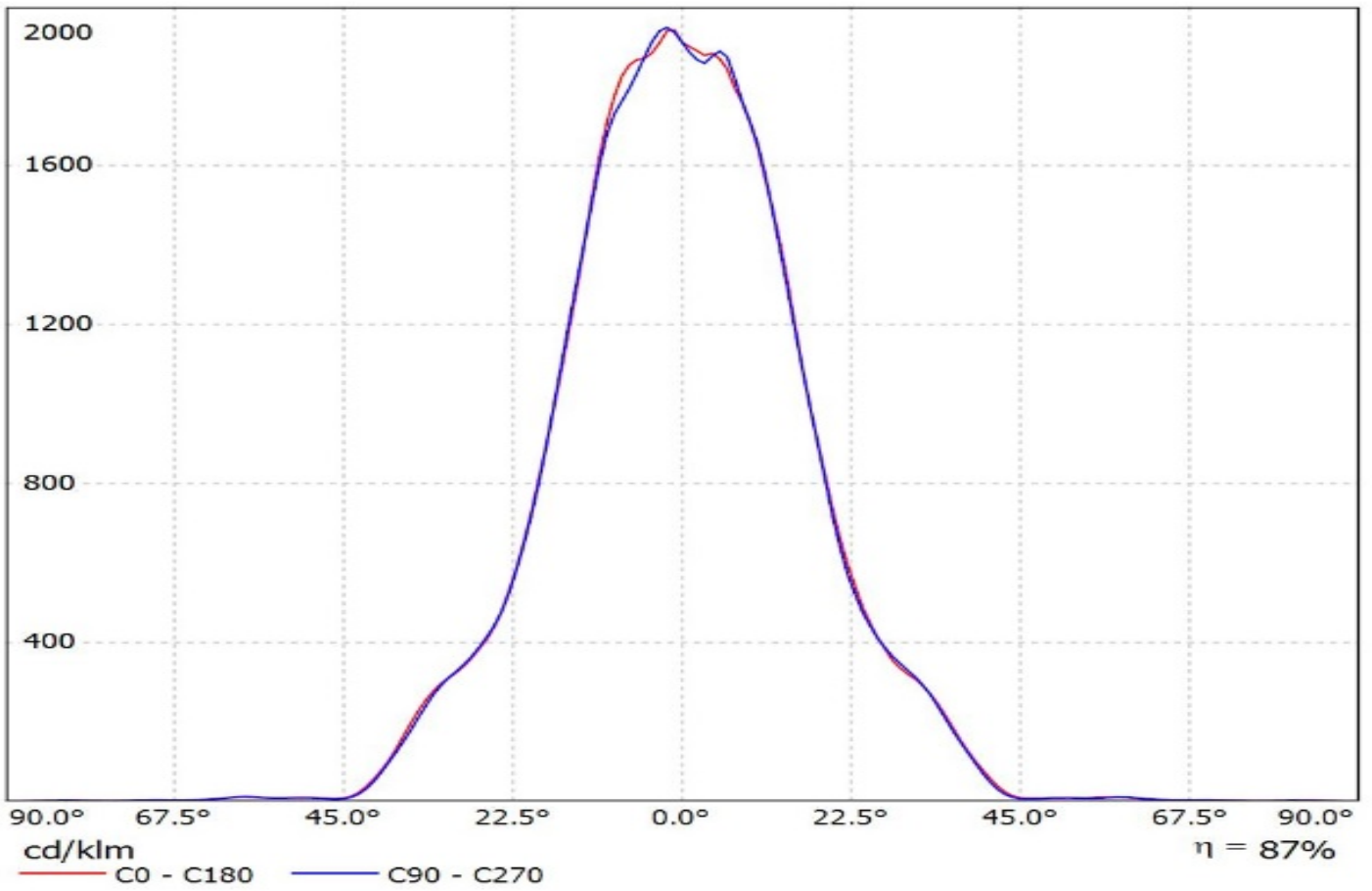

Luminaire: LEDil Oy CN13518_MIRELLA-50-M-CL_(ZC6) Efficiency=82%
Lamps: 1 x Seoul ZC6 (SDW81F1C) 422lm @ 100mA CCT=3100K P=3.4W I=100mA

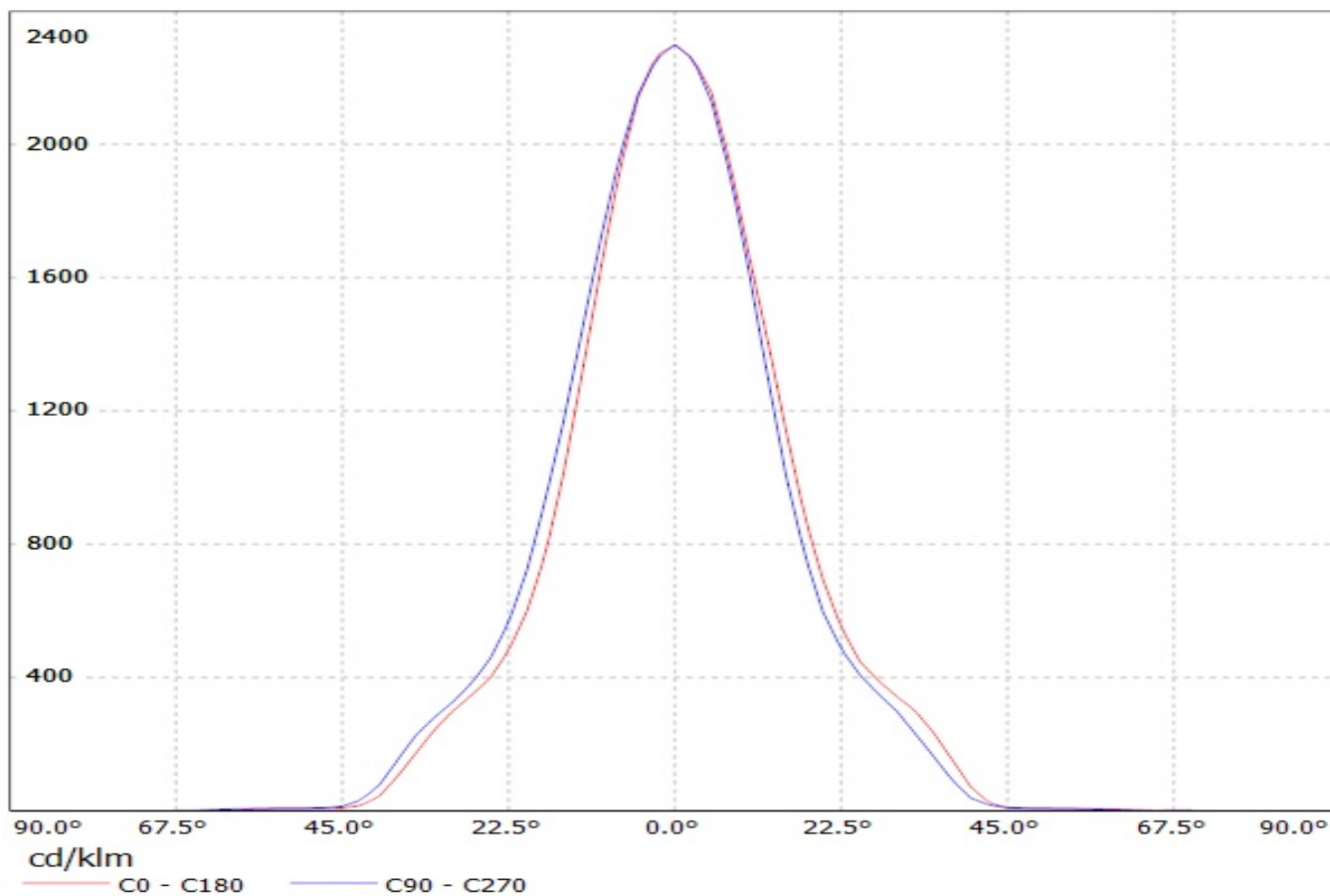

Luminaire: LEDil Oy CN13518_MIRELLA-50-M-CL_(Stark_SLE_G3_LES10) Efficiency=81%
Lamps: 1 x Tridonic Stark SLE G3 LES10 (STARK-SLE-PURE-G3-10-1000-830-CLA) 453lm @ 250mA CCT=3000K P=4.3W I=250mA

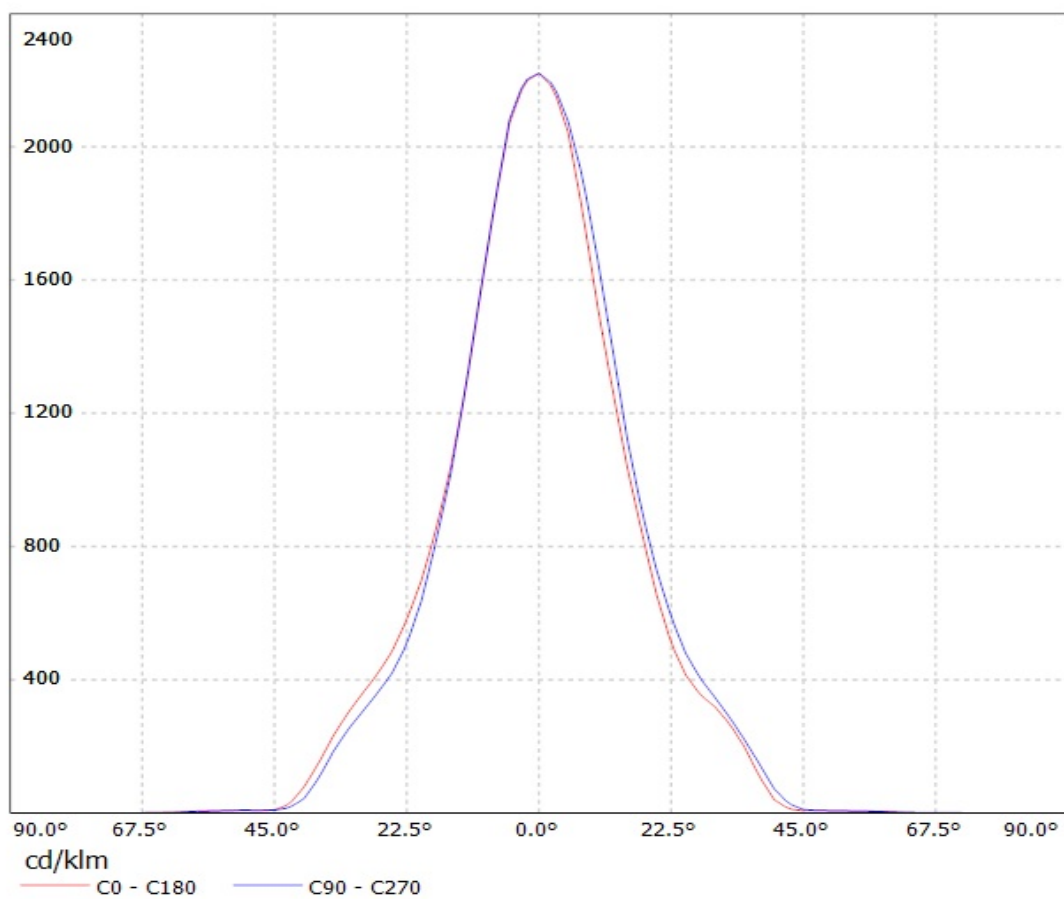

Ledil CN13518_MIRELLA-50-M-CL_(CLU720) / LDC (Polar)

Luminaire: Ledil CN13518_MIRELLA-50-M-CL_(CLU720)
Lamps: 1 x CITIZEN_CLU720_(CLU720-1206B8-273M2)
_1298.17lm@250mA_CCT=2700K_P=8.3W_I=0.25A

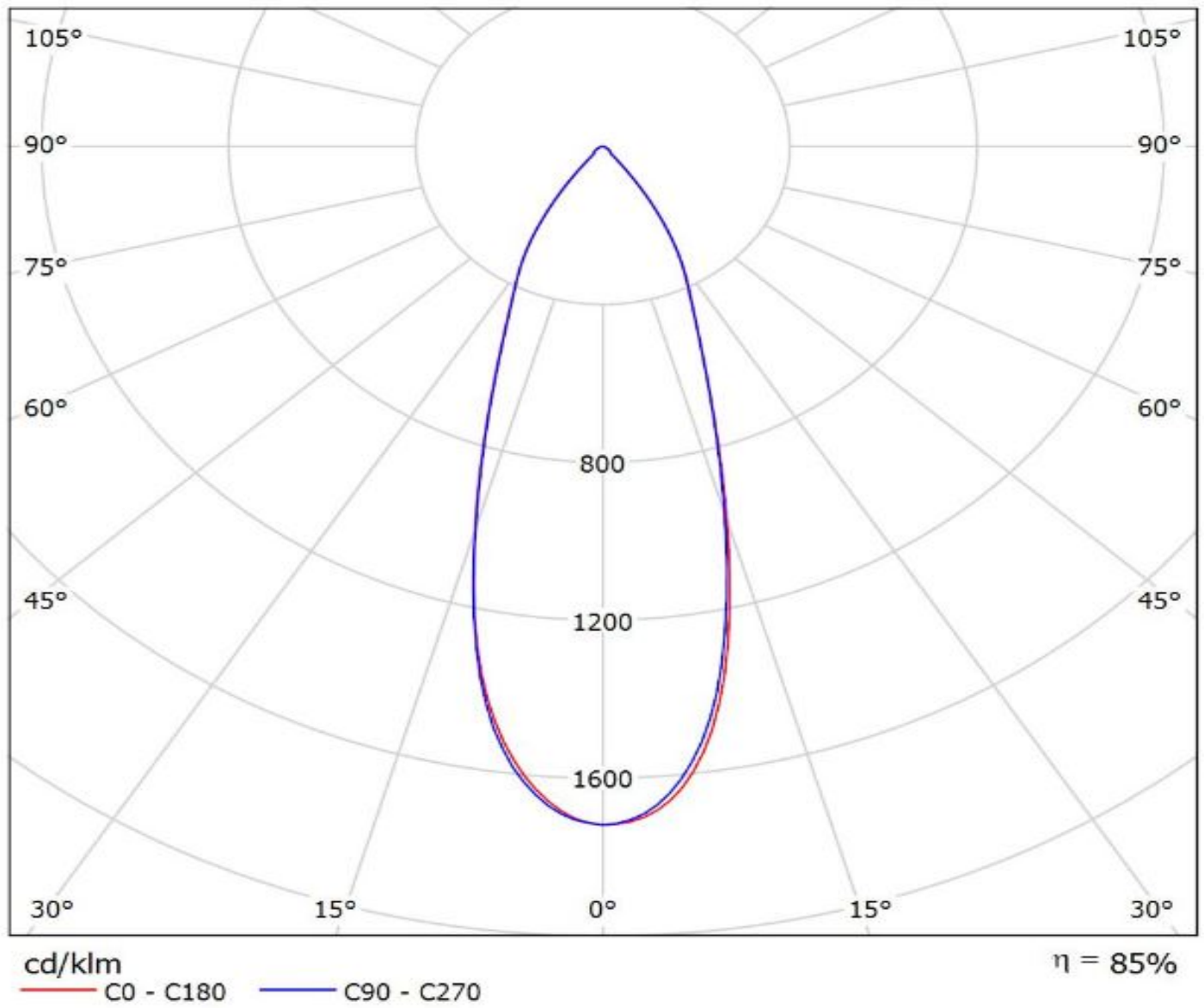

Luminaire: Ledil CN13518_MIRELLA-50-M-CL_(CLU710)

Lamps: 1 x CITIZEN_CLU710_(CLU710-1204B8-273M2G1)_1212.66lm@250mA_P=8.5W_I=0.25A

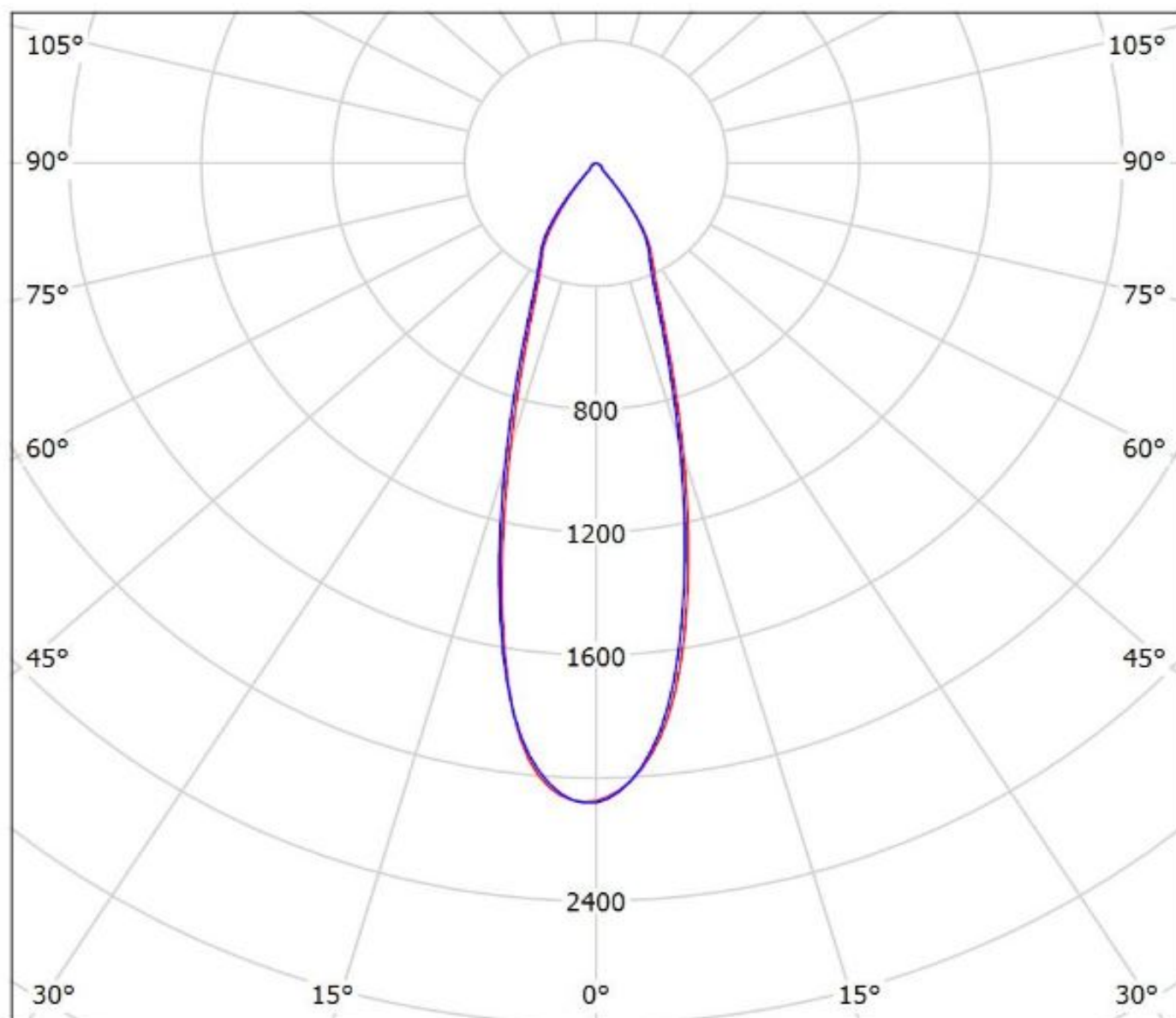

cd/klm

— C0 - C180

— C90 - C270

η = 85%

Luminaire: Ledil CN13518_MIRELLA-50-M-CL_(CLU700)

Lamps: 1 x Citizen_CLU700_395.592lm@100mA_P=2.815W_I=0.1A

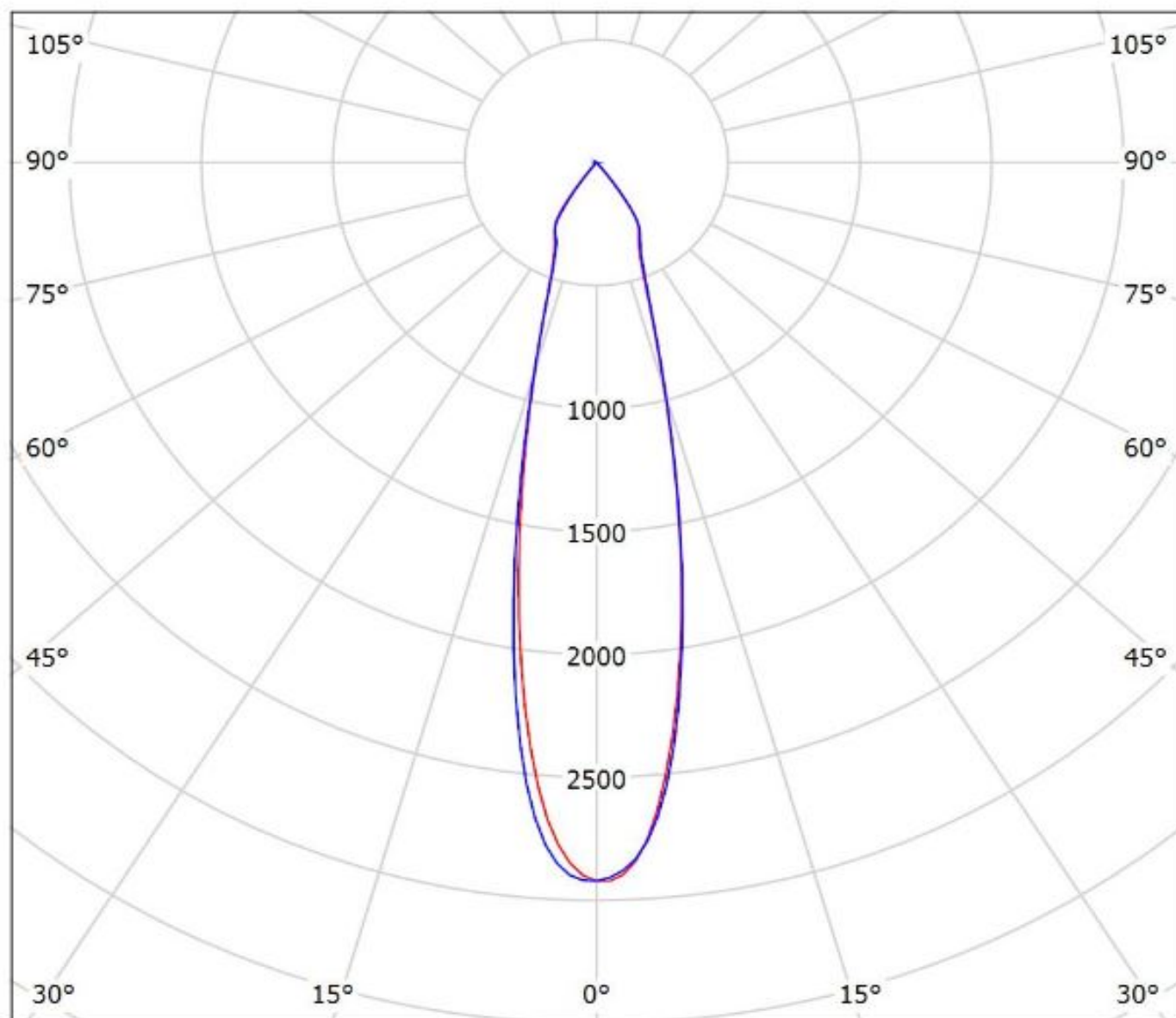

cd/klm

— C0 - C180 — C90 - C270

$\eta = 83\%$

Luminaire: LEDiL Oy CN13518_MIRELLA-50-M-CL_(CREE_XHP50_WARM_WHITE)
Lamps: 1 x CREE_XHP50_WARM_WHITE_194.925lm@250mA_P=1.39897W_η=0.2499A

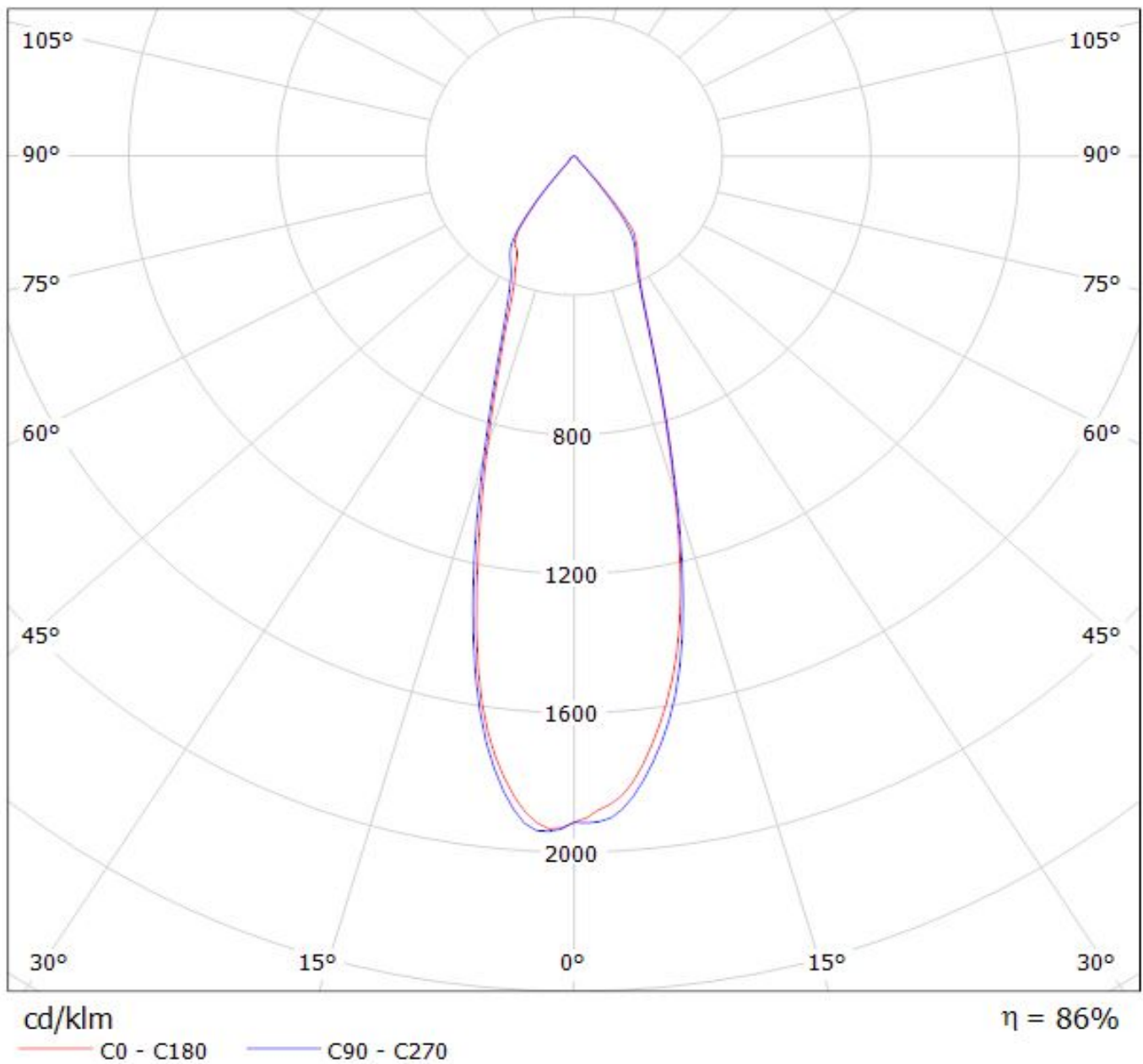

Luminaire: LEDiL Oy CN13518_MIRELLA-50-M-CL_(Cree_XHP70)
Lamps: 1 x Cree_XHP70_258.083lm@250mA_P=1.38117W_I=0.2499A

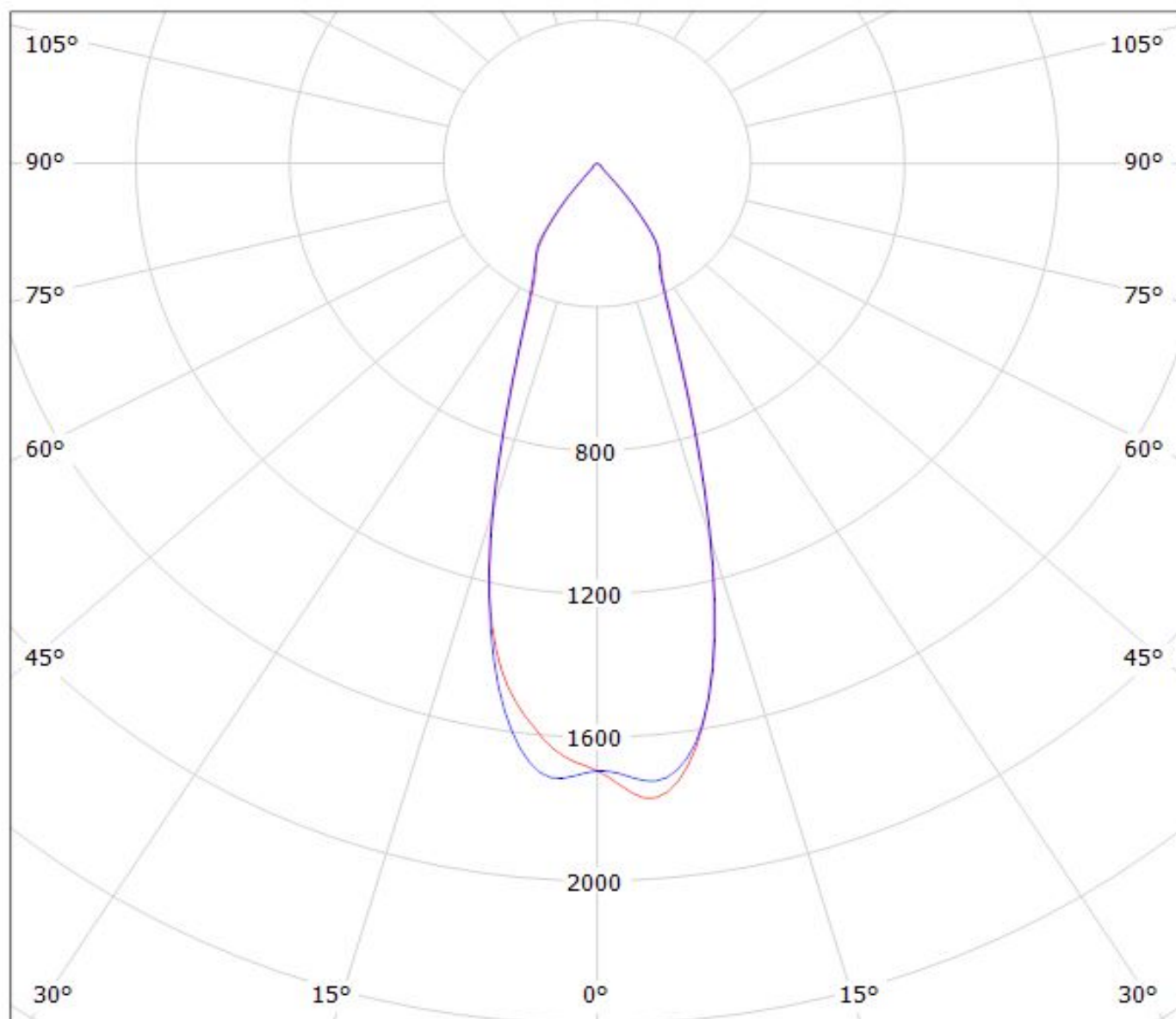

cd/klm

— C0 - C180 — C90 - C270

$\eta = 86\%$

Luminaire: Ledil CN13518_MIRELLA-50-M-CL_(MHD-G)
Lamps: 1 x Cree MHD-G_528.649lm@100mA_P=3.0W_I=0.100A

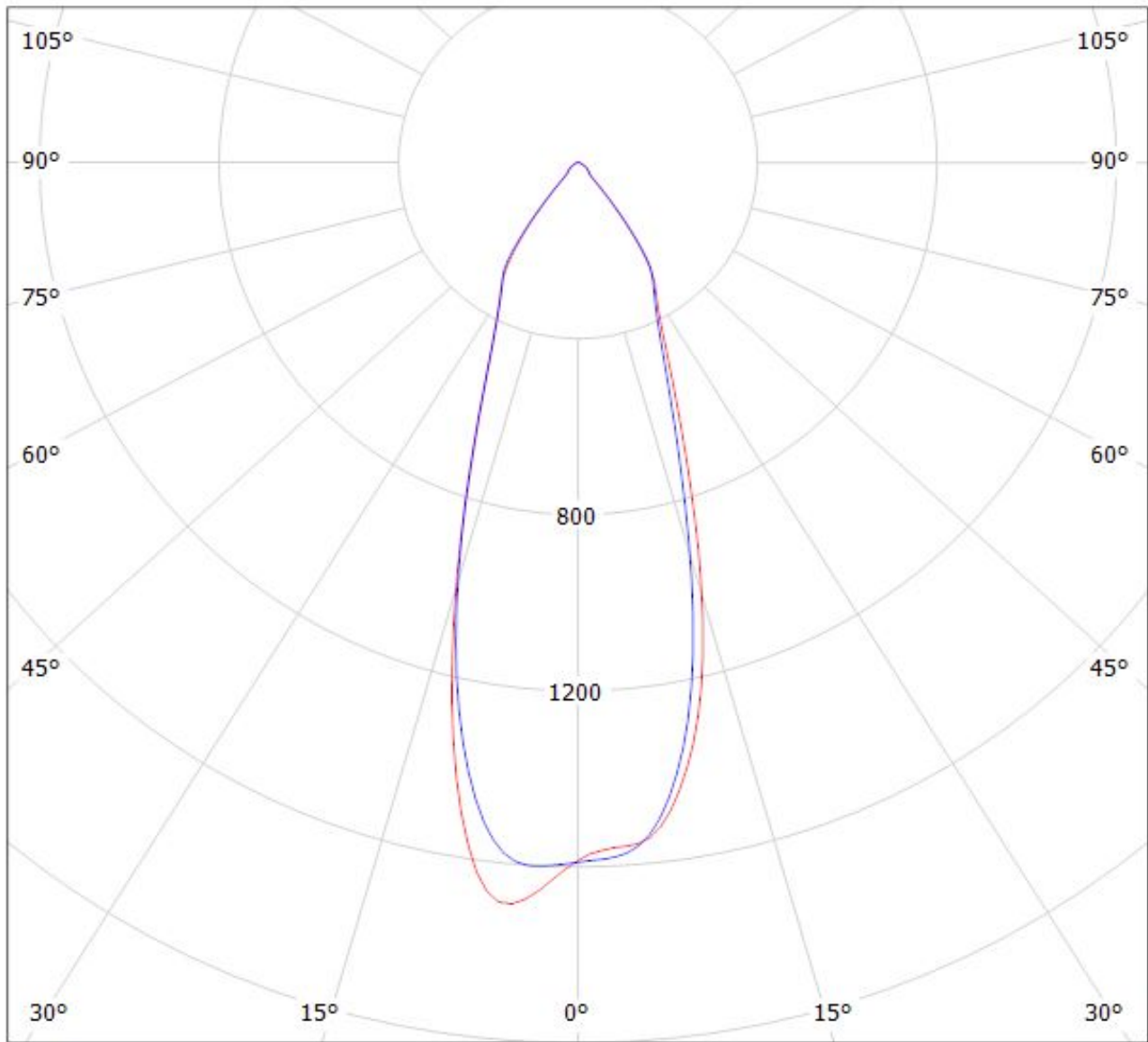

cd/klm

— C0 - C180 — C90 - C270

$\eta = 88\%$

Luminaire: Ledil Oy CN13518_MIRELLA-50-M-CL_(Luxeon_CoB_1203) Efficiency=85%
Lamps: 1 x Luxeon Cob 1203 (LHC1-3080-1203) 824lm @ 250mA CCT=3000K P=8.7W I=250mA

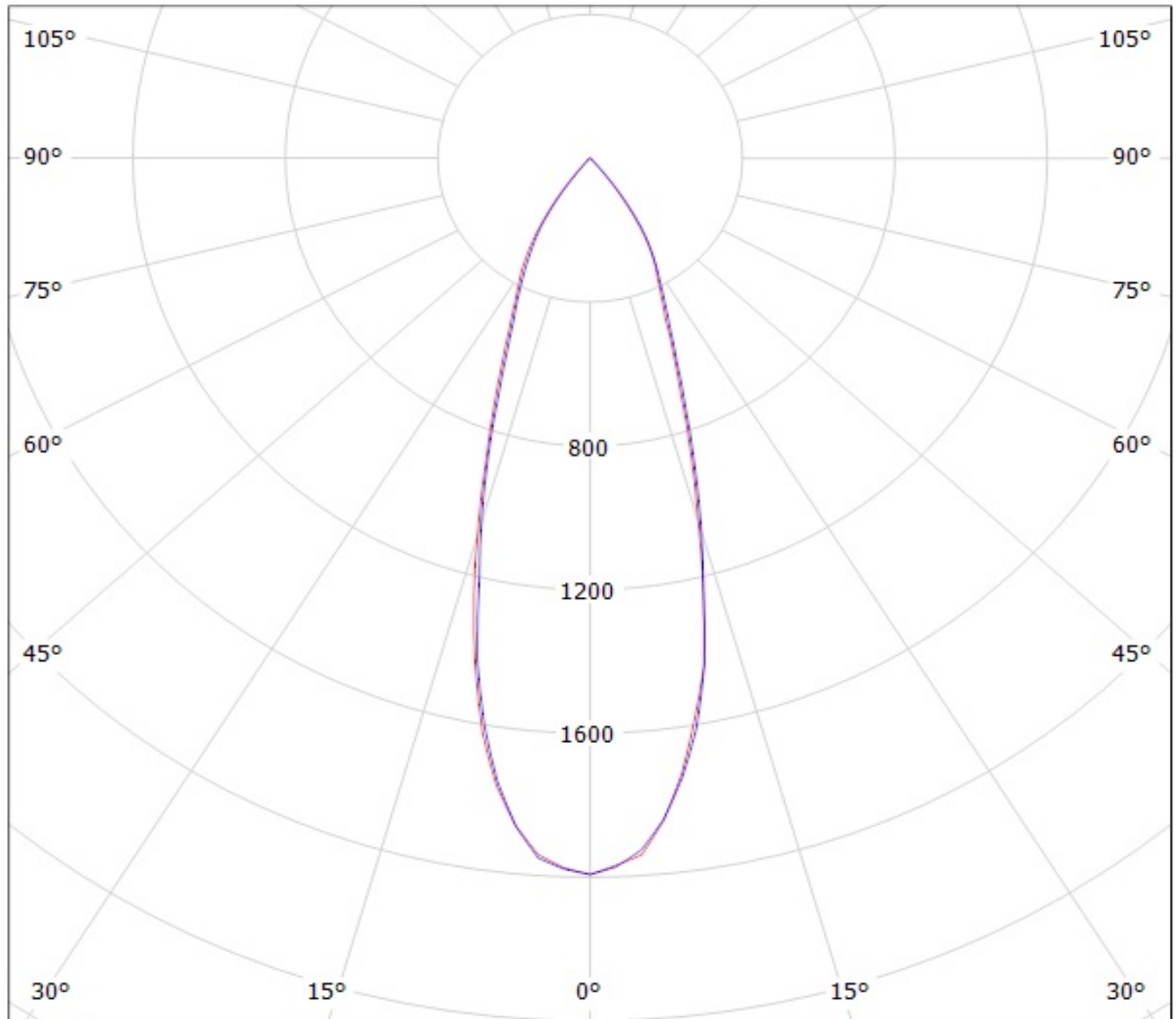

cd/klm

— C0 - C180 — C90 - C270

Luminaire: LEDiL Oy CN13518_MIRELLA-50-M-CL_(CXM-9)

Lamps: 1 x Luminus_XNOVA_CXM-9_(AA00)_974.297lm@240mA_P=8.2836W_I=240mA

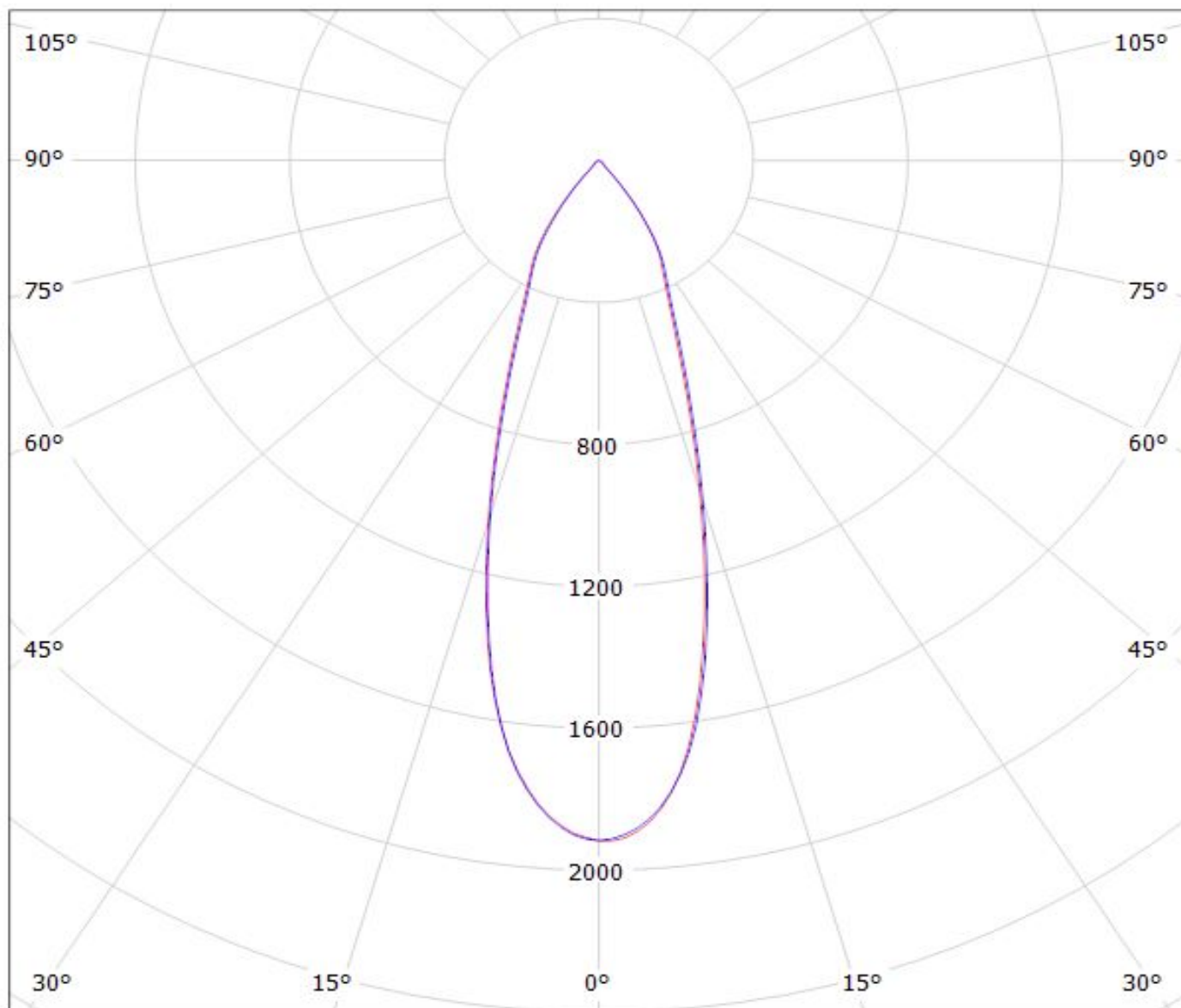

cd/klm

$\eta = 85\%$

— C0 - C180 — C90 - C270

Luminaire: Ledil Oy CN13518_MIRELLA-50-M-CL (NSBxL066A 930lm @ 250mA) Efficiency=86%
Lamps: 1 x NSBxL066A 930lm @ 250mA (NSBLL066AE) CCT=3536K P=7,75W I=250mA

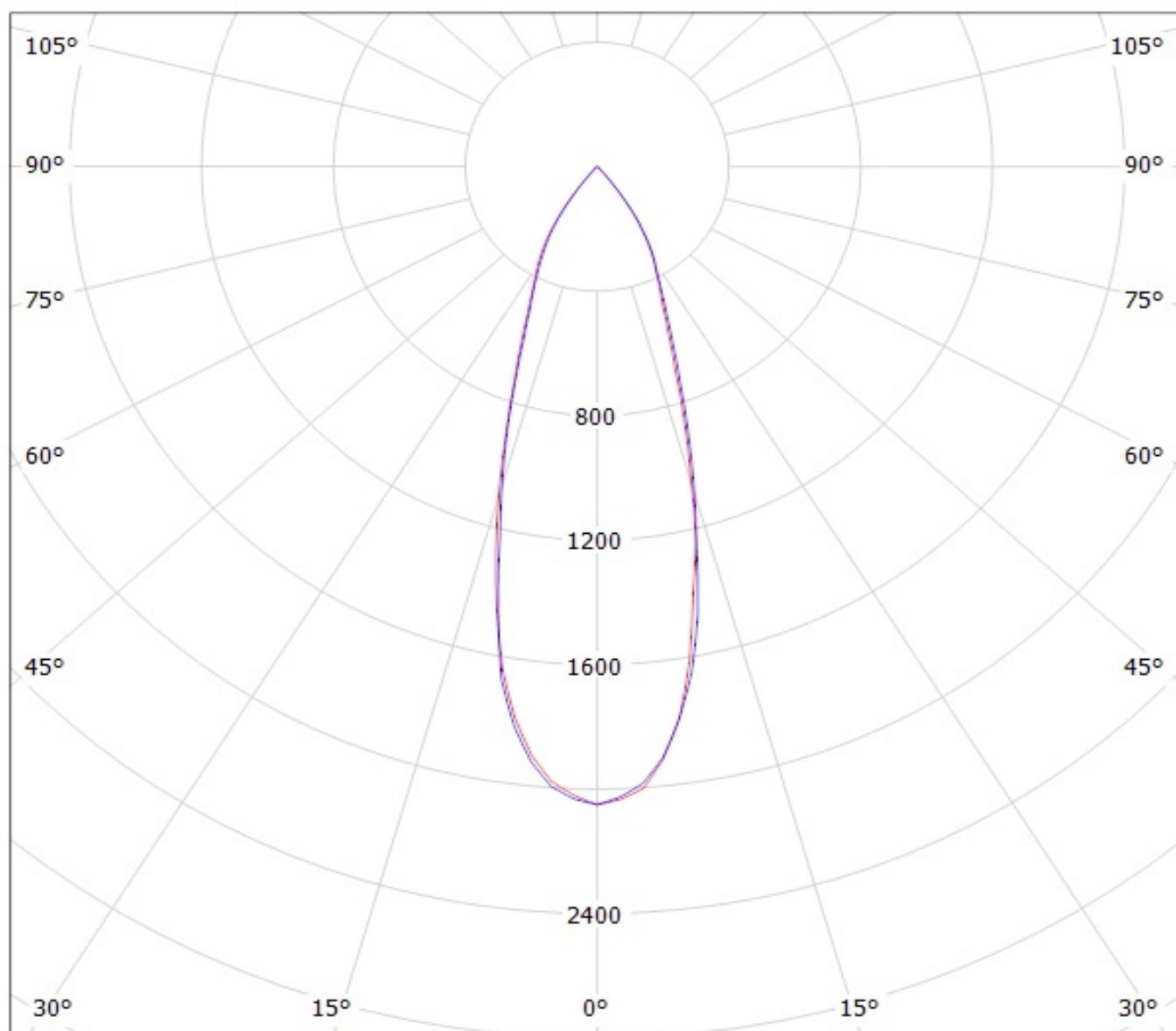

cd/klm

— C0 - C180

— C90 - C270

Luminaire: Ledil Oy CN13518_MIRELLA-50-M-CL (Nichia NSCxL036A 434lm @ 100mA) Efficiency=85%
Lamps: 1 x Nichia NSCxL036A 434lm @ 100mA (NSCLL036A) CCT=3000K P=3,4W I=100mA

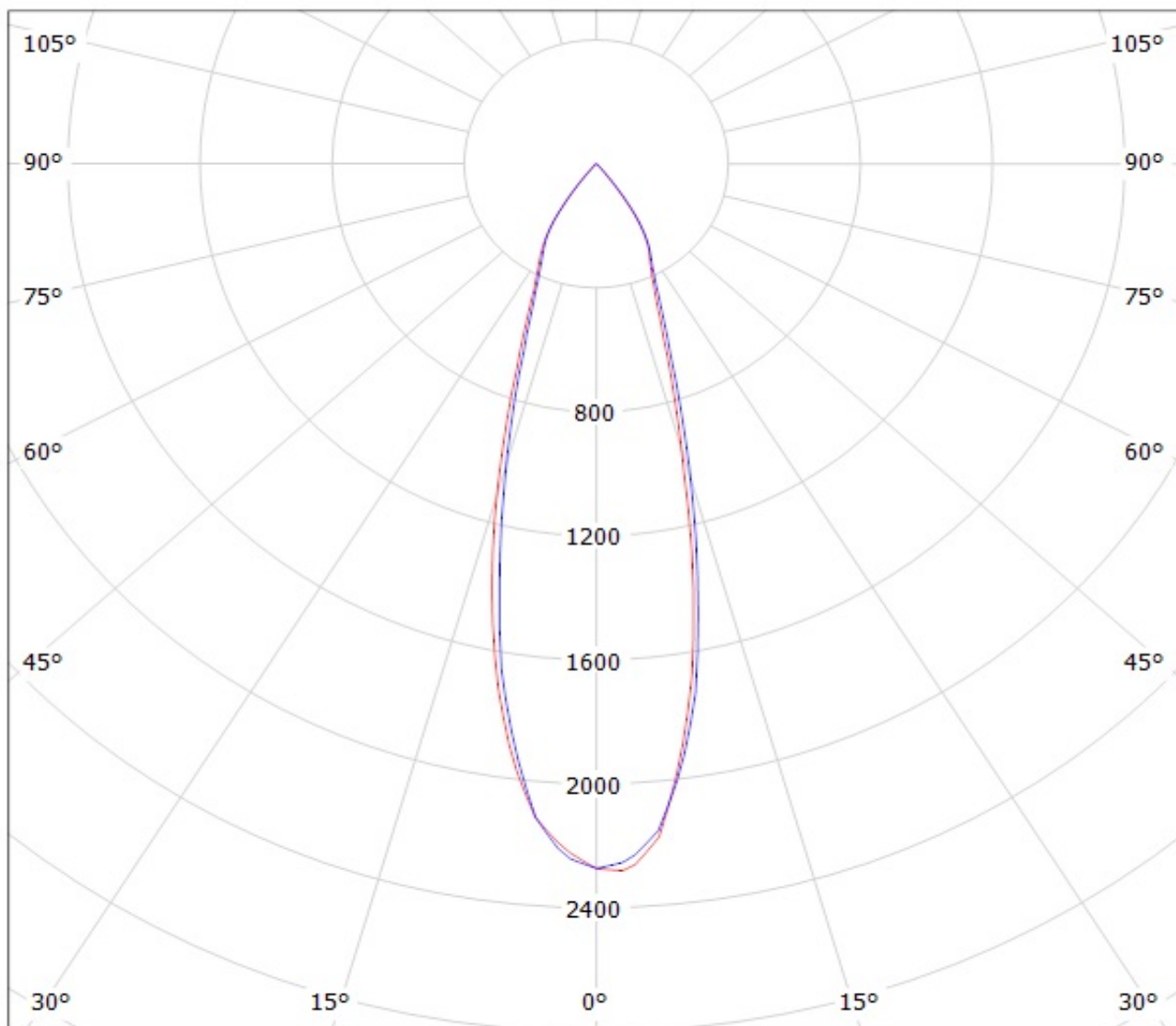

cd/klm

— C0 - C180 — C90 - C270

Luminaire: LEDil Oy CN13518_MIRELLA-50-M-CL_(Soleriq_S13) Efficiency=82%
Lamps: 1 x Osram Soleriq S13 (GW KAGHB1.EM) 832lm @ 250mA CCT=3100K P=7.4W I=250mA

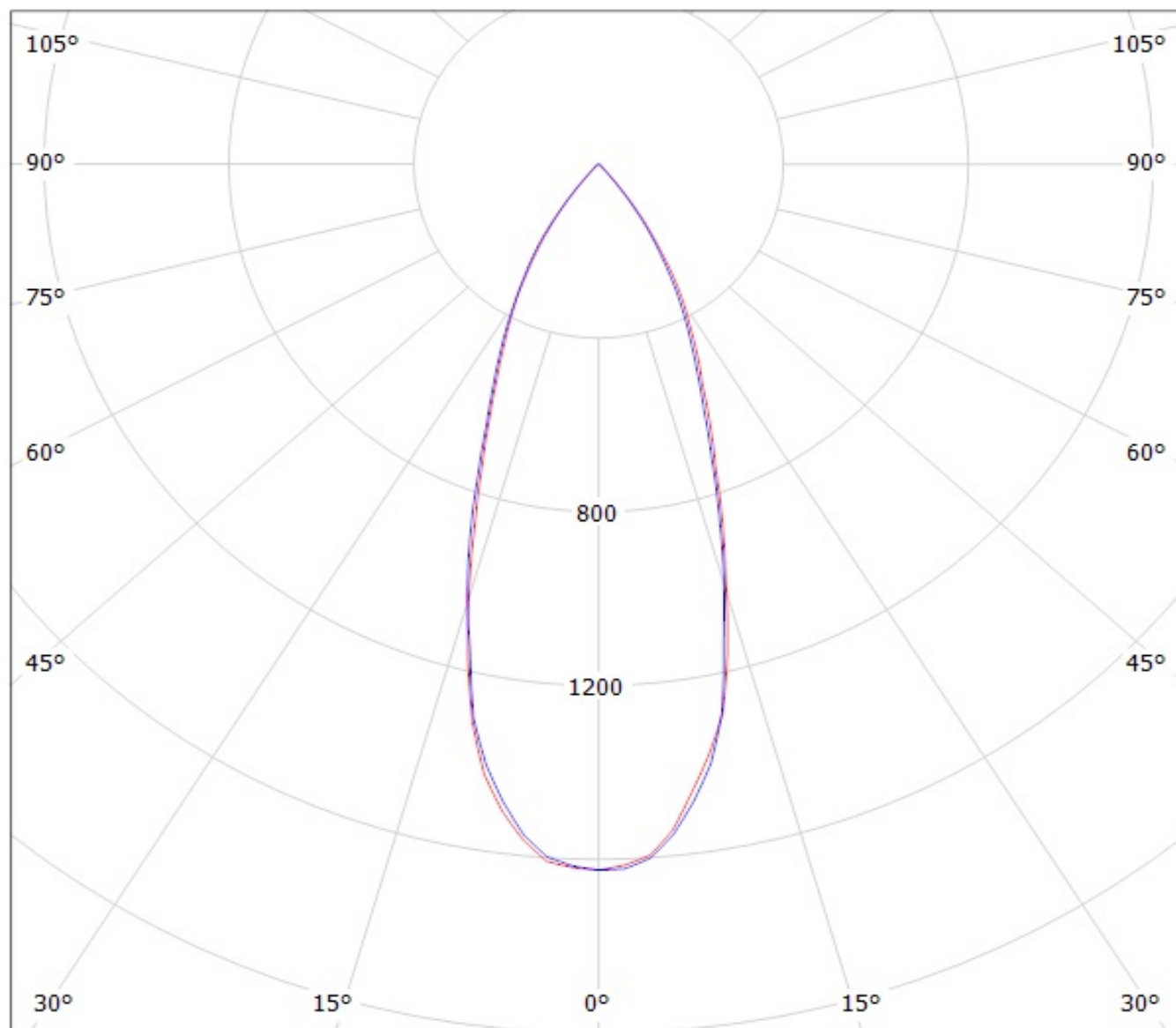

cd/klm

— C0 - C180 — C90 - C270

Luminaire: Ledil Oy CN13518_MIRELLA-50-M-CL_(Soleriq_S9)_SIMULATED
Lamps: 1 x Osram Soleriq S9 (GW KAFJB3.EM)

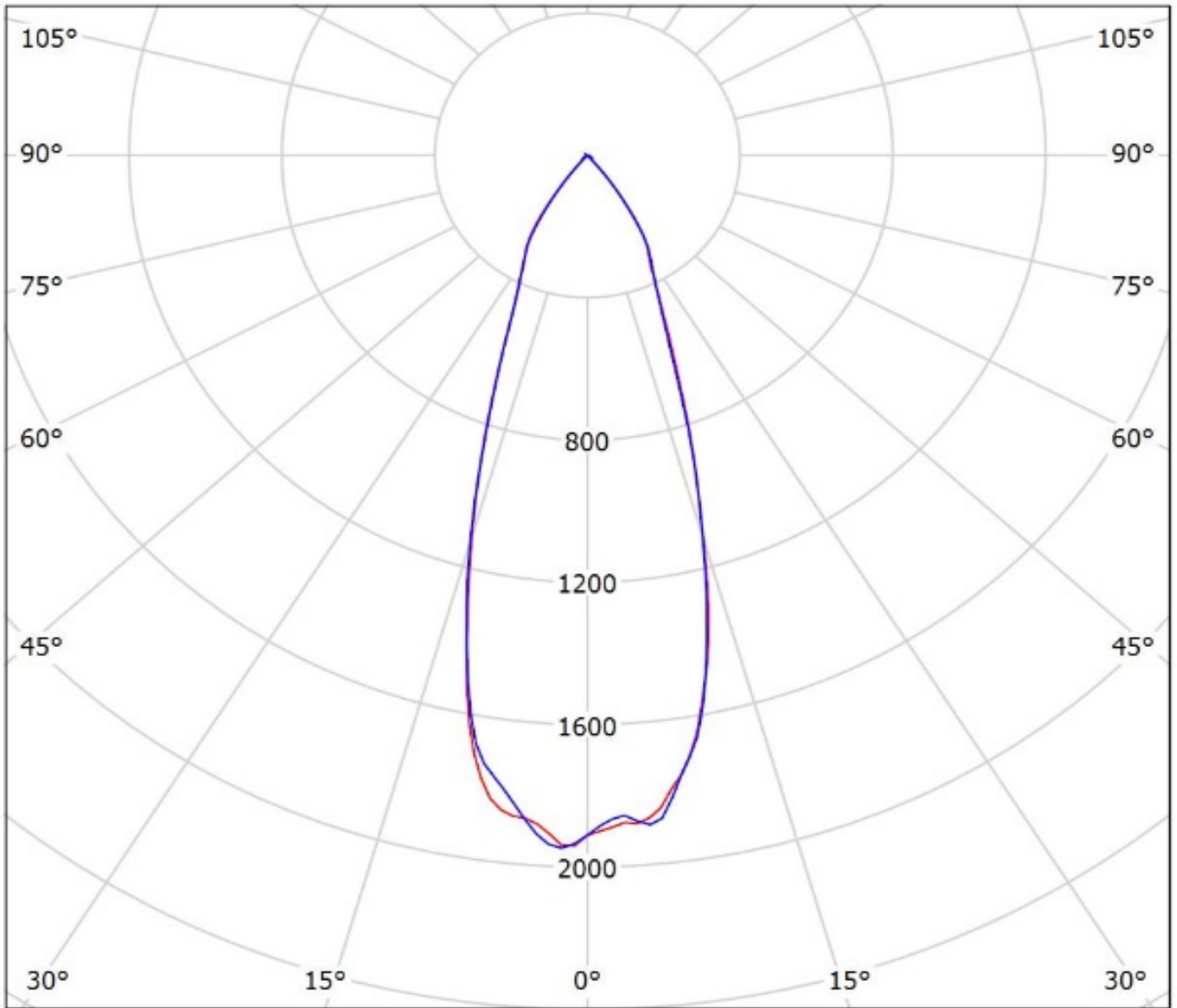

cd/klm
— C0 - C180 — C90 - C270

$\eta = 87\%$

Luminaire: LEDil Oy CN13518_MIRELLA-50-M-CL_(ZC6) Efficiency=82%
Lamps: 1 x Seoul ZC6 (SDW81F1C) 422lm @ 100mA CCT=3100K P=3.4W I=100mA

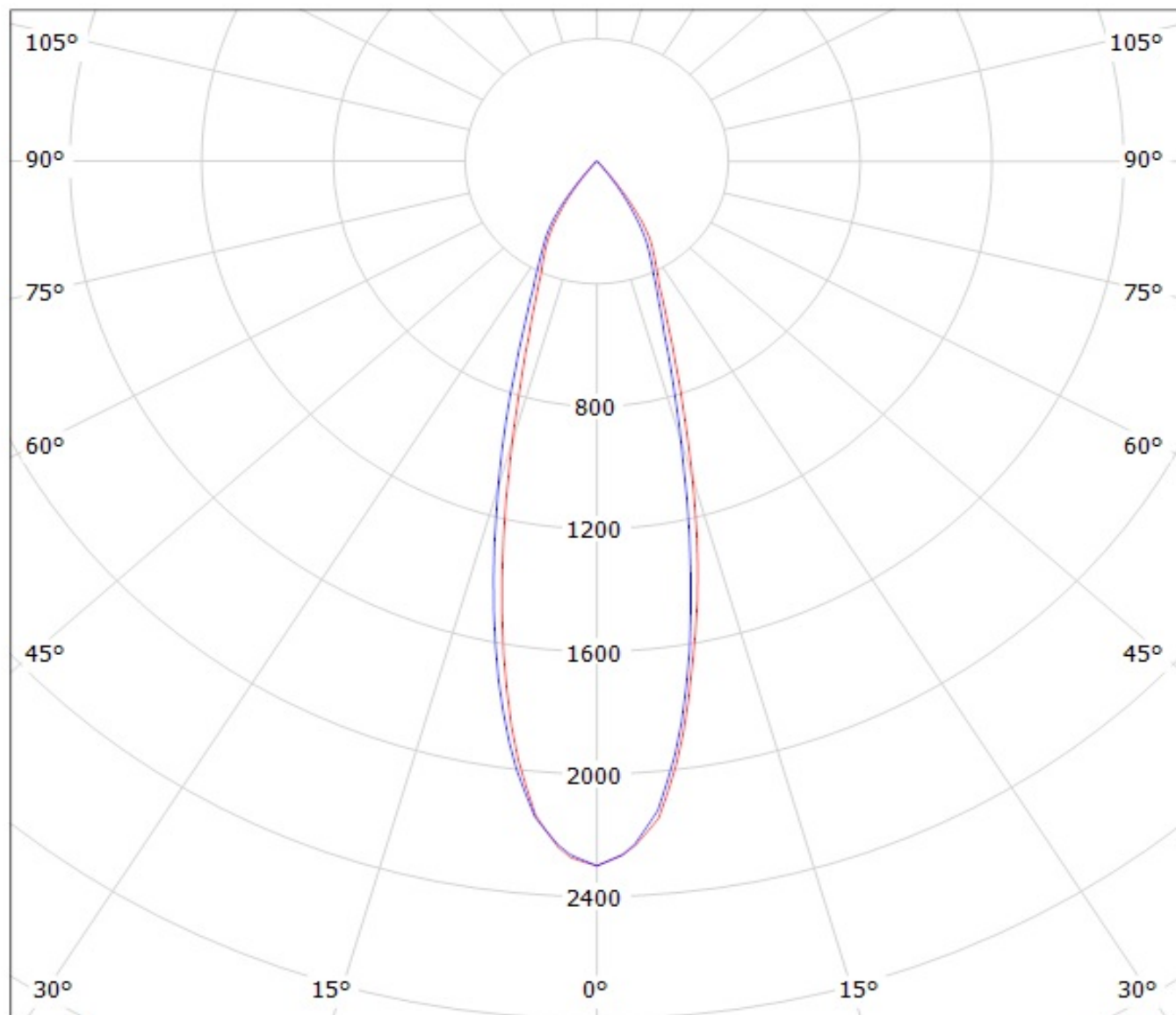

cd/klm

— C0 - C180 — C90 - C270

$\eta = 83\%$

Luminaire: LEDil Oy CN13518_MIRELLA-50-M-CL_(Stark_SLE_G3_LES10) Efficiency=81%
Lamps: 1 x Tridonic Stark SLE_G3_LES10 (STARK-SLE-PURE-G3-10-1000-830-CLA) 453lm @ 250mA CCT=3000K P=4.3W I=250mA

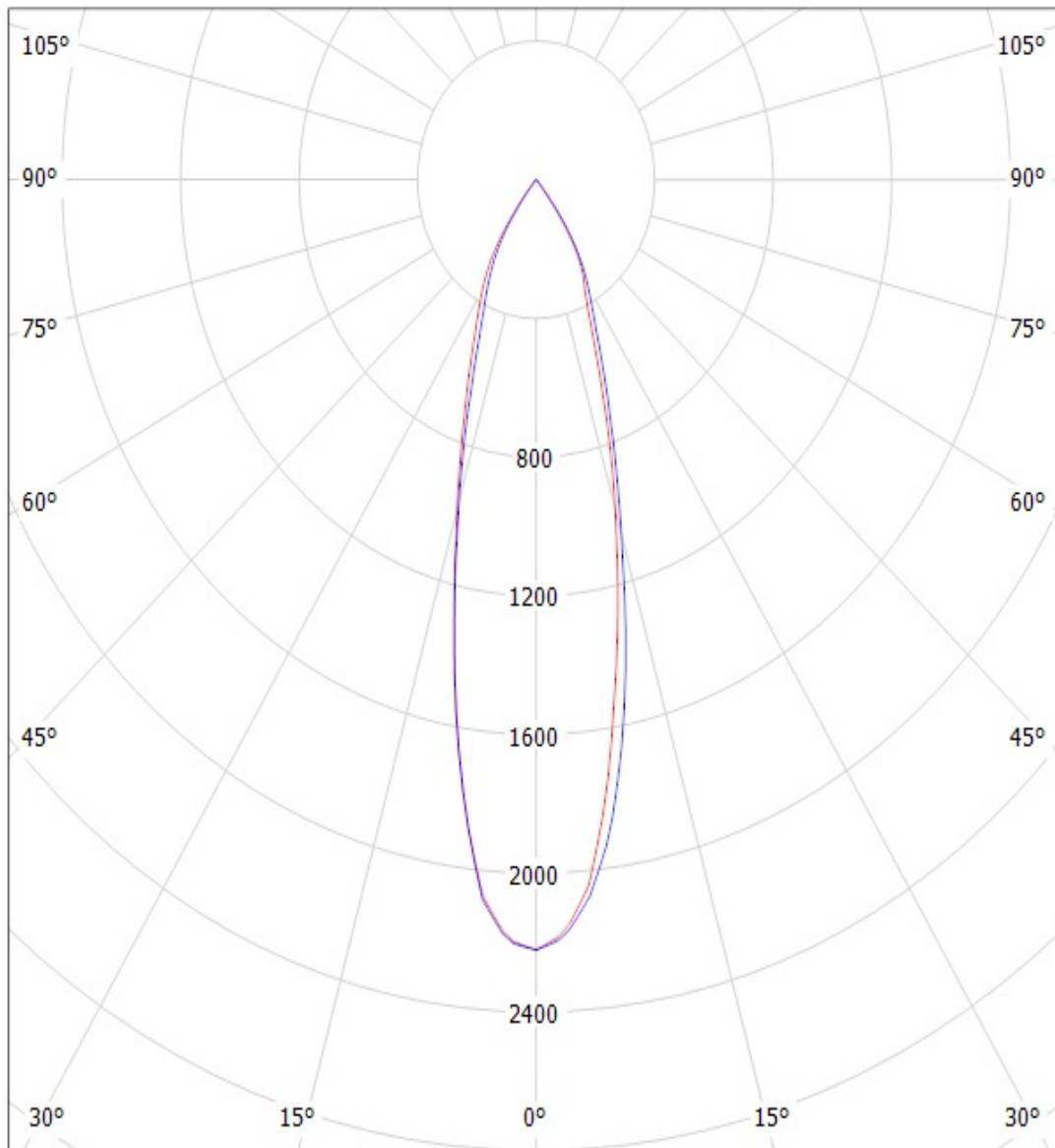

cd/klm

— C0 - C180

— C90 - C270

NOTE: The typical divergence will be changed by different color, chip size and chip position tolerance. The typical total divergence is the full angle measured where the luminous intensity is half of the peak value.

GENERAL INFORMATION

- Product series especially designed & optimized for series of LEDs.
- Special care taken to make light distribution as uniform as possible.

Note! Due to use of high power COB's with this product, special attention to proper thermal design is highly recommended. LEDiL has no liability for direct, indirect or consecutive damages arising from the LEDiL products being used outside of the recommended temperature range.