

| REVISIONS | | | | |
|-----------|---------|-----------------|------------|----|
| REV. | ECO. NO | DESCRIPTION | DATE | BY |
| A | 2146 | INITIAL RELEASE | 07/16/2010 | LH |

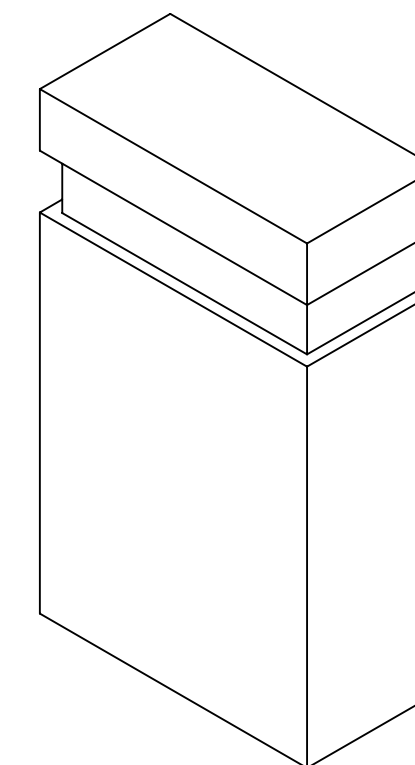

SECTION A - A

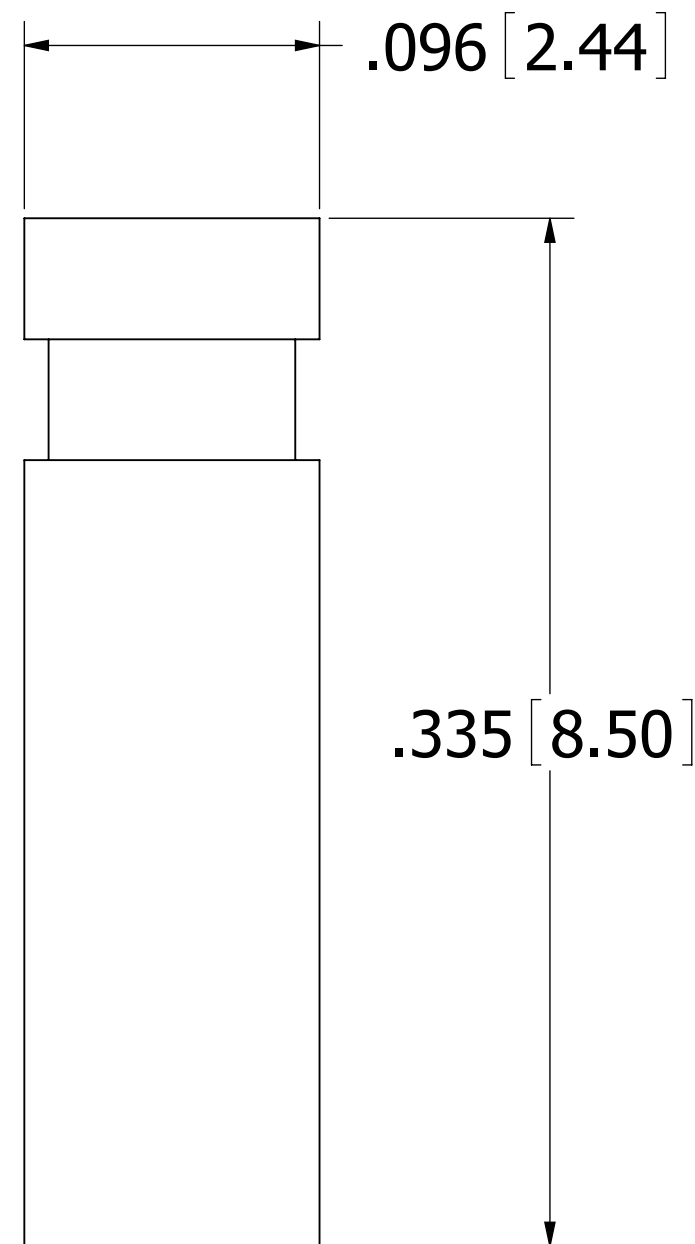
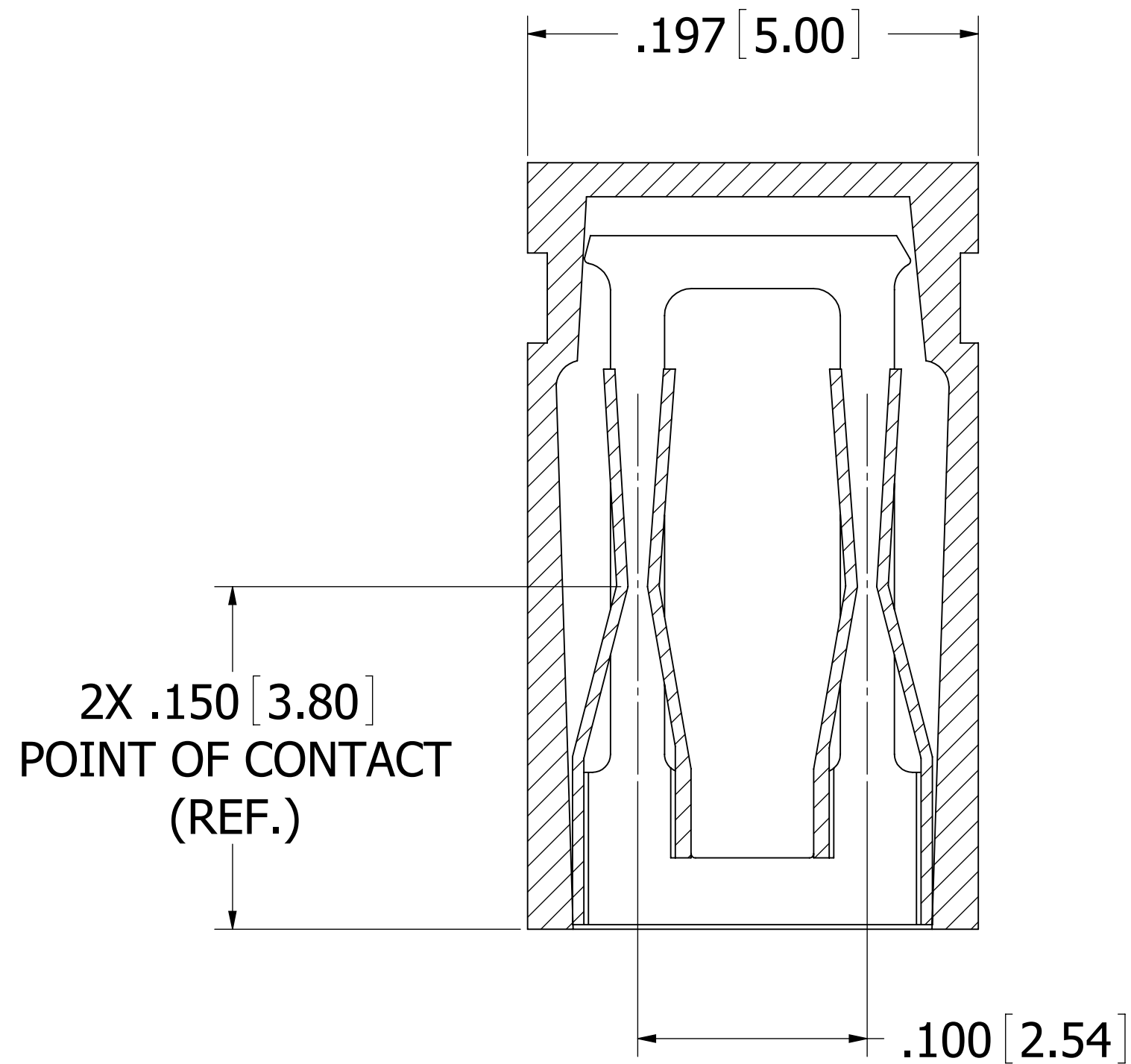
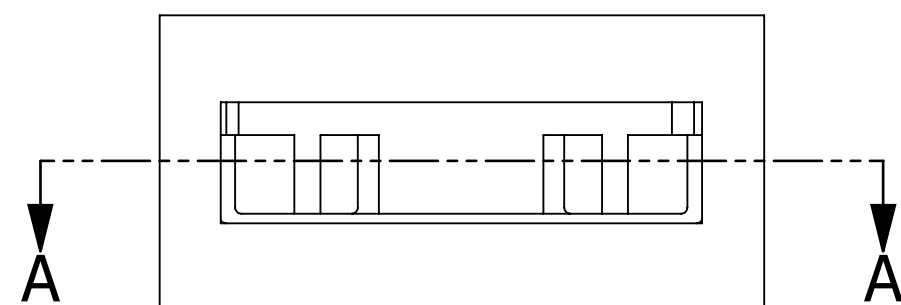

NOTES:

1. INSULATOR MATERIAL: PBT.
2. CONTACT MATERIAL: PHOSPHOR BRONZE.
3. PLATING: GOLD FLASH OVERALL.
4. UL FLAMMABILITY RATING: 94V-0.
5. DIELECTRIC WITHSTANDING VOLTAGE: 650V AC.
6. CURRENT RATING: 3 AMPS PER CONTACT.
7. CONTACT RESISTANCE: 30 MILLI OHMS MAX.
8. INSULATION RESISTANCE: 1000 MEGA OHMS.
9. OPERATING TEMPERATURE: -40° TO +85 °C
10. DOUBLE TUNING FORK TYPE CONTACT, ACCOMMODATES .025"[0.64mm] SQ PINS.
.100"[2.54mm] PITCH LOW-PROFILE MINI TYPE.

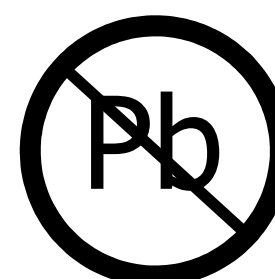

RoHS COMPLIANT

UNLESS OTHERWISE SPECIFIED:
DIMENSIONS ARE IN INCHES[MM]
TOLERANCES:
ANGULAR: ± 30°
.XX=± .012 [.30]
.XXX=± .008 [.20]
.XXXX=± .004 [.10]

INTERPRET DIMENSIONS AND GEOMETRIC TOLERANCING PER: ASME Y14.5M-2009

| | | | |
|-----------------------------------------------------------------------------------------------------------------------------------------------------------------------------------------------------------------------------------------------------------|-----------|--------------|--------------------------------------------------------|
| DRAWN | DATE | NAME | |
| LH | 7/16/2010 | LH | |
| <small>THE INFORMATION HEREIN CONTAINS PROPRIETARY INFORMATION OF SULLINS ELECTRONICS AND IS NOT TO BE REPRODUCED, USED OR DISCLOSED TO OTHERS FOR ANY PURPOSE EXCEPT AS SPECIFICALLY AUTHORIZED IN WRITING BY AN OFFICER OF SULLINS ELECTRONICS.</small> | | | DESCRIPTION MINI SHUNT, .100" CC, CLOSED TOP |
| SIZE DWG. NO. | | | PART NUMBER SPC02SVJN-RC |
| C | | 11513 | REV A |
| SCALE: 16:1 | | | SHEET 1 OF 1 |